

# Introduction to Turbulence and Heating in the Solar Wind

Ben Chandran

University of New Hampshire

NASA LWS Summer School, Boulder, CO, 2012

# Outline

- I. Introduction to Turbulence
- II. Measurements of Turbulence in the Solar Wind.
- III. Magnetohydrodynamics (MHD)
- IV. Alfvén Waves, the Origin of the Solar Wind, and Solar Probe Plus
- V. Introduction to phenomenological theories of MHD turbulence.

# What Is Turbulence?

Operational definition for turbulence in plasmas and fluids: *turbulence consists of disordered motions spanning a large range of lengthscales and/or timescales.*

# “Energy Cascade” in Hydrodynamic Turbulence

Canonical picture: larger eddies break up into smaller eddies

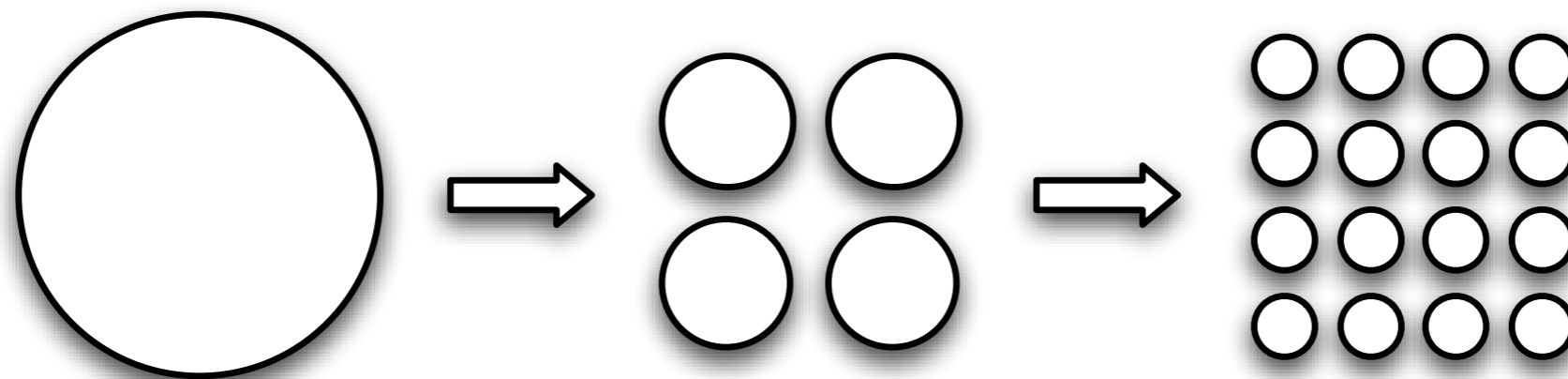

ENERGY  
INPUT

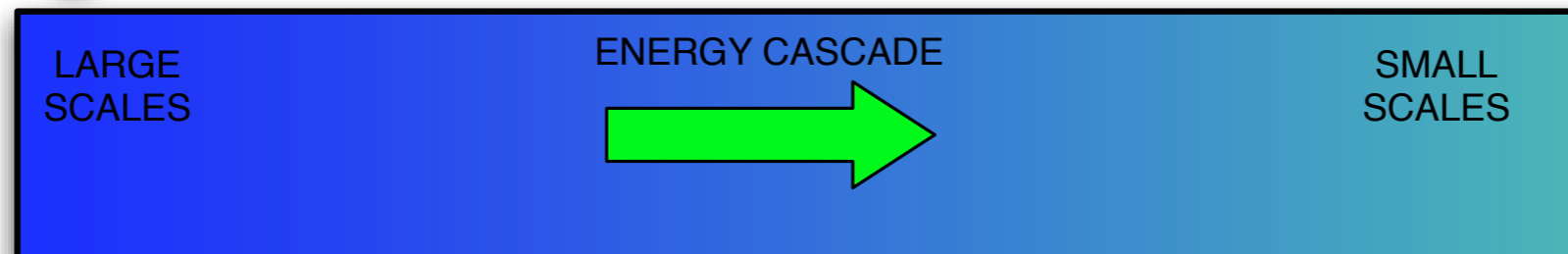
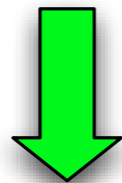

A thick green arrow pointing downwards from the 'SMALL SCALES' section of the energy cascade diagram to the text 'DISSIPATION OF FLUCTUATION ENERGY'.

DISSIPATION  
OF FLUCTUATION  
ENERGY

# Plasma Turbulence Vs. Hydro Turbulence

- In plasmas such as the solar wind, turbulence involves electric and magnetic fields as well as velocity fluctuations.
- In some cases the basic building blocks of turbulence are not eddies but plasma waves or wave packets.

# Where Does Turbulence Occur?

- Atmosphere (think about your last plane flight).
- Oceans.
- Sun, solar wind, interstellar medium, intracluster plasmas in clusters of galaxies...

# What Causes Turbulence?

- Instabilities: some source of free energy causes the amplification of fluctuations which become turbulent. Example: convection in stars.
- Stirring. Example: stirring cream into coffee.
- Requirement: the medium can't be too viscous. (Stirring a cup of coffee causes turbulence, but stirring a jar of honey does not.)

# What Does Turbulence Do?

- Turbulent diffusion or mixing. Examples: cream in coffee, pollutants in the atmosphere.
- Turbulent heating. When small-scale eddies (or wave packets) dissipate, their energy is converted into heat. Example: the solar wind.



# Outline

- ✓ I. Introduction to Turbulence
- II. Measurements of Turbulence in the Solar Wind.
- III. Magnetohydrodynamics (MHD)
- IV. Alfvén Waves, the Origin of the Solar Wind, and Solar Probe Plus
- V. Introduction to phenomenological theories of MHD turbulence.

# In Situ Measurements

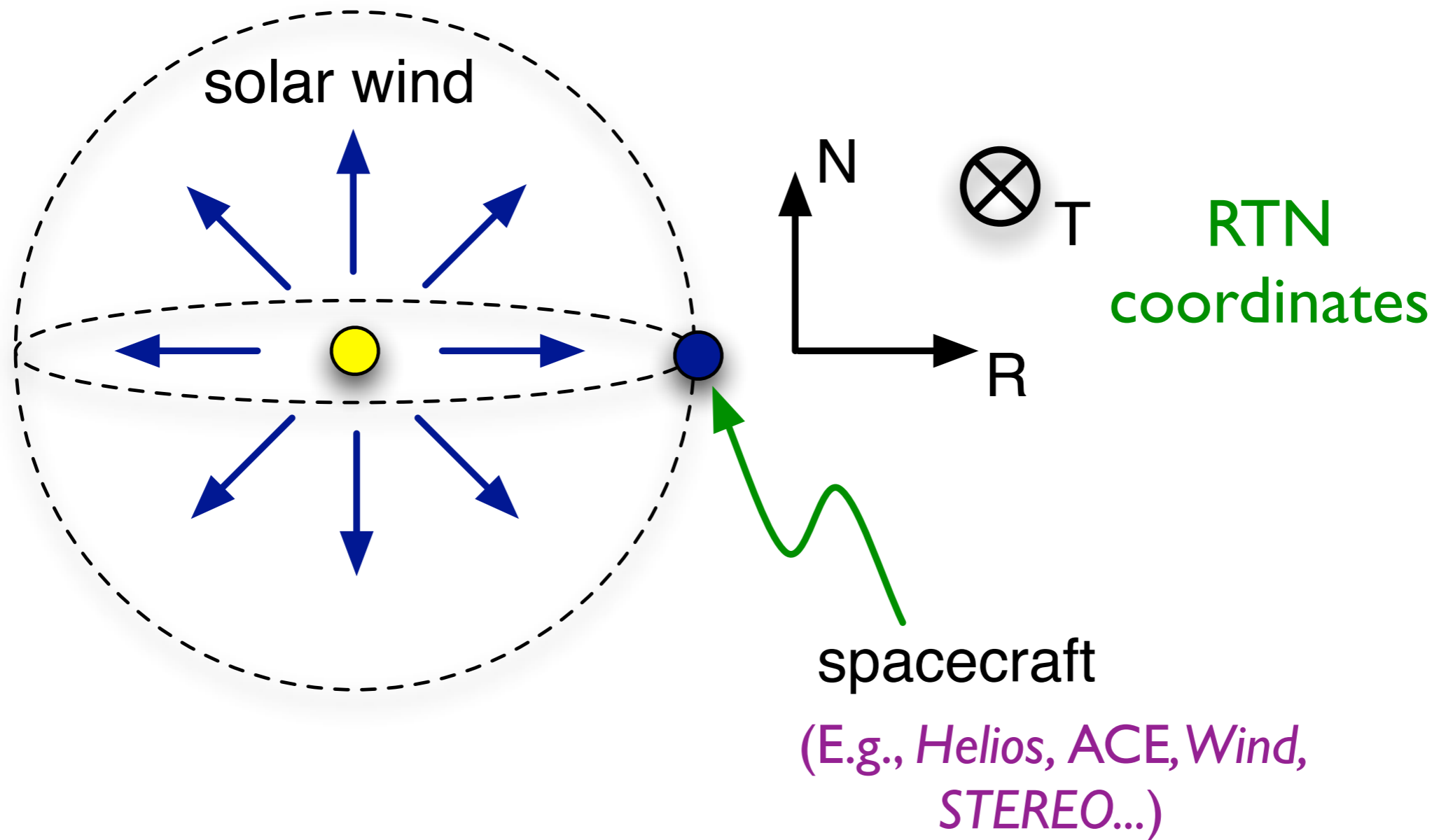

Quantities measured include  $\mathbf{v}$ ,  $\mathbf{B}$ ,  $\mathbf{E}$ ,  $n$ , and  $T$

# Spacecraft Measurements of the Magnetic Field and Velocity

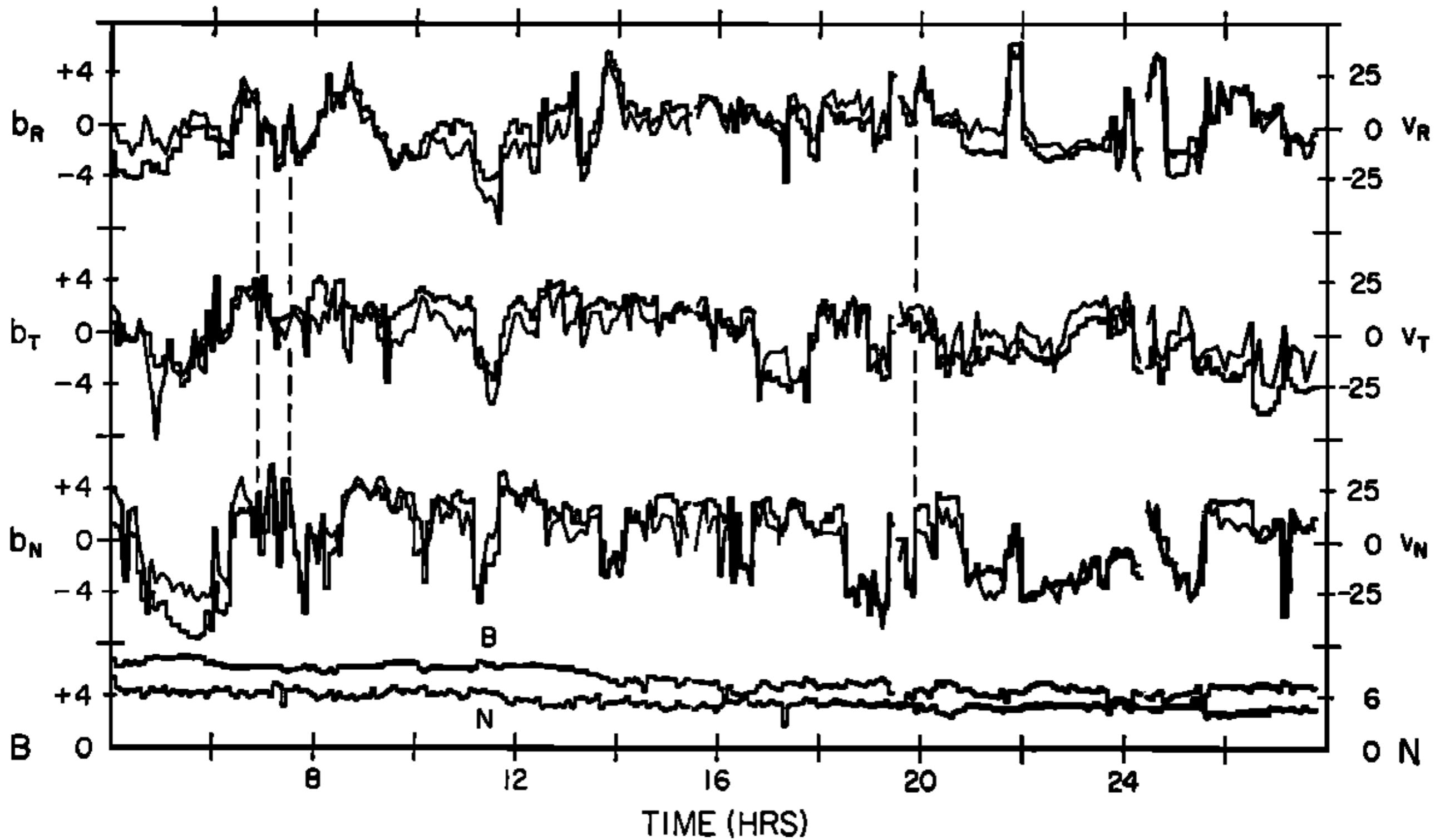

Data from the *Mariner 5* spacecraft (Belcher & Davis 1971)

## ALFVÉN WAVES IN SOLAR WIND

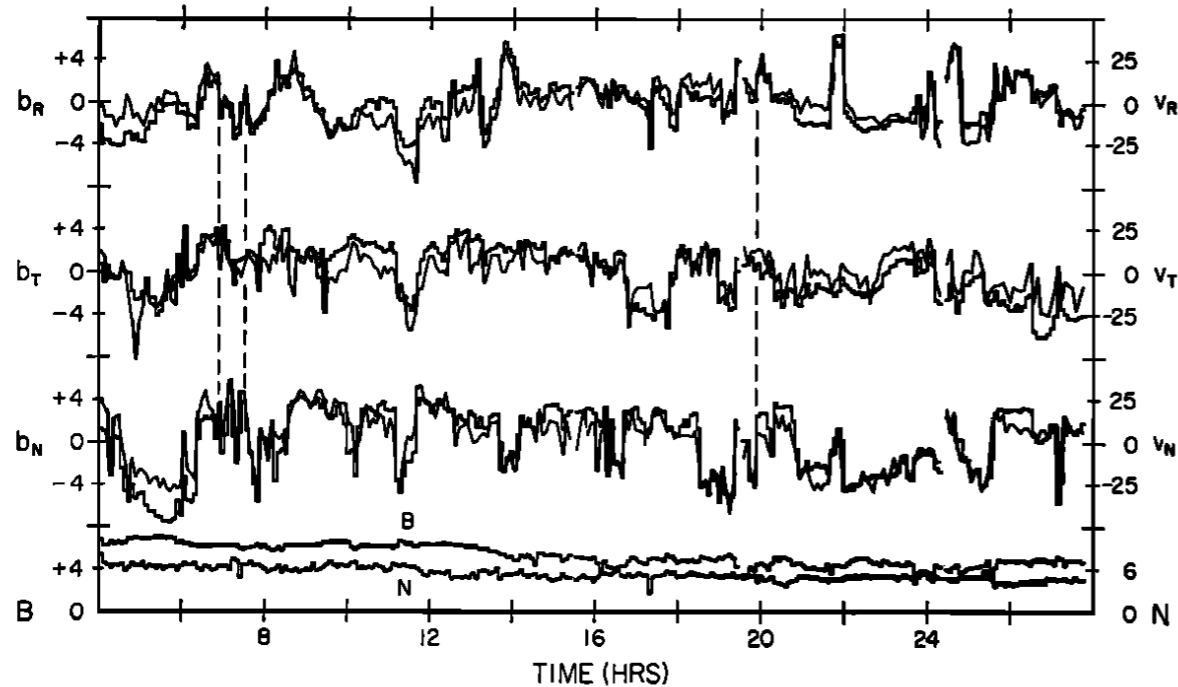

## Is This Turbulence?

- The velocity and magnetic field in these measurements appear to fluctuate in a random or disordered fashion.
- But how do we tell whether there are “velocity fluctuations spanning a large range of scales,” as in our operational definition of turbulence?
- One way: by examining the power spectrum of the fluctuations.

# The Magnetic Power Spectrum

Fourier transform  
of magnetic field

$$\vec{\tilde{B}}(f) = \lim_{T \rightarrow \infty} \int_{-T/2}^{T/2} \vec{B}(t) e^{2\pi i f t} dt$$

power spectrum

$$P(f) = \lim_{T \rightarrow \infty} \frac{1}{T} \langle \vec{\tilde{B}}(f) \cdot \vec{\tilde{B}}(-f) \rangle$$

- $B(t)$  is the magnetic field vector measured at the spacecraft location.
- $T$  is the duration of the measurements considered. (When power spectra are computed using real data,  $T$  can not be increased indefinitely; the resulting power spectra are then approximations of the above formulas.)
- $\langle \dots \rangle$  indicates an average over many such measurements.

# The Magnetic Power Spectrum

$$\vec{\tilde{B}}(f) = \lim_{T \rightarrow \infty} \int_{-T/2}^{T/2} \vec{B}(t) e^{2\pi i f t} dt$$

$$P(f) = \lim_{T \rightarrow \infty} \frac{1}{T} \langle \vec{\tilde{B}}(f) \cdot \vec{\tilde{B}}(-f) \rangle$$

- $\vec{\tilde{B}}(f)$  can be thought of as the part of  $B$  that oscillates with frequency  $f$ .
- When turbulence is present,  $P(f)$  is non-negligible over a broad range of frequencies. Typically,  $P(f)$  has a power-law scaling over frequencies varying by one or more powers of 10.

# Magnetic Power Spectra in the Solar Wind

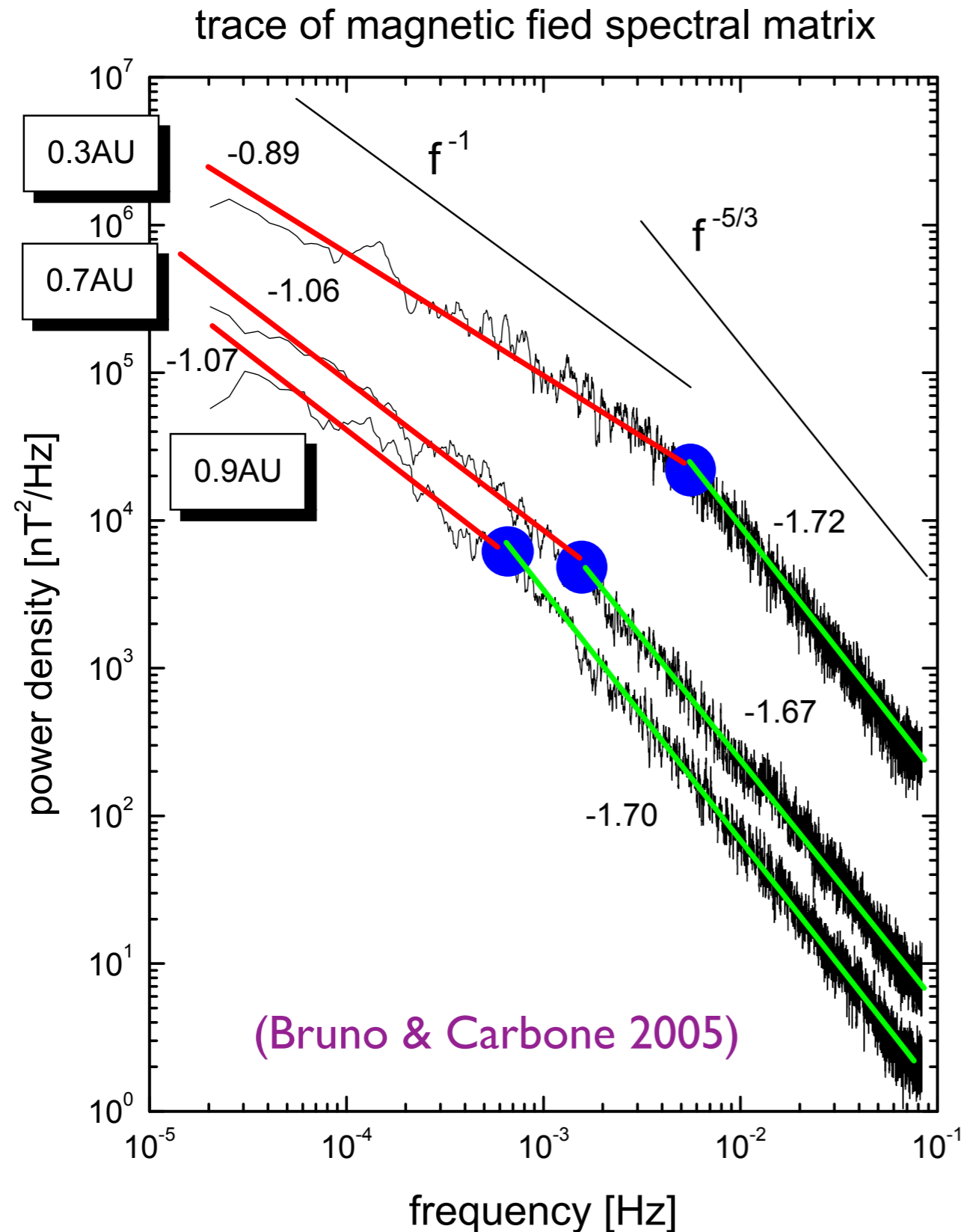

Is This Turbulence?

Yes - the magnetic fluctuations measured by the spacecraft span a broad range of timescales.

Similar spectra are observed at all locations explored by spacecraft in the solar wind.

# What Causes the Time Variation Seen in Spacecraft Measurements?

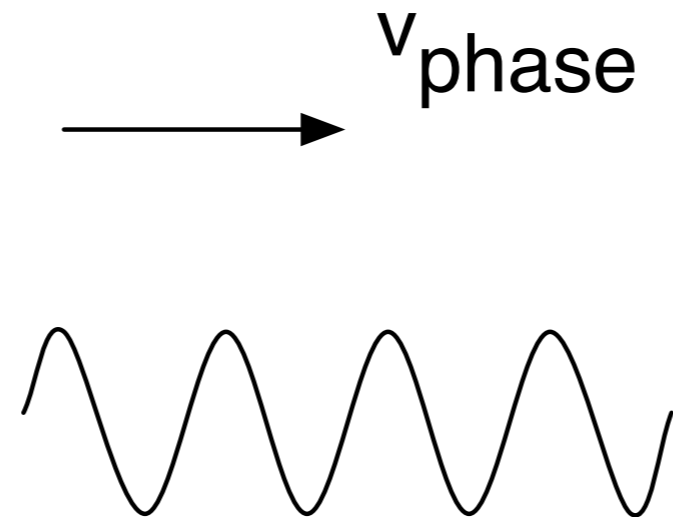

- Consider a traveling plasma wave (more on plasma waves soon). *Imagine you're viewing this wave as you move away from the Sun at the same velocity as the solar wind.* From your perspective, the time variation of the magnetic field is the result of the wave pattern moving past you at the wave phase speed *relative to the solar-wind plasma*,  $v_{\text{phase}}$ , which is typically  $\approx 30$  km/s in the solar wind near Earth.
- If the wavenumber of the wave is  $k$ , the angular frequency of the magnetic field in this case is  $kv_{\text{phase}}$ . This frequency characterizes the “intrinsic time variations” of the magnetic field in the solar wind frame.



# But What if You Measure $B$ Using a “Stationary” Spacecraft That Does Not Move with the Solar Wind?

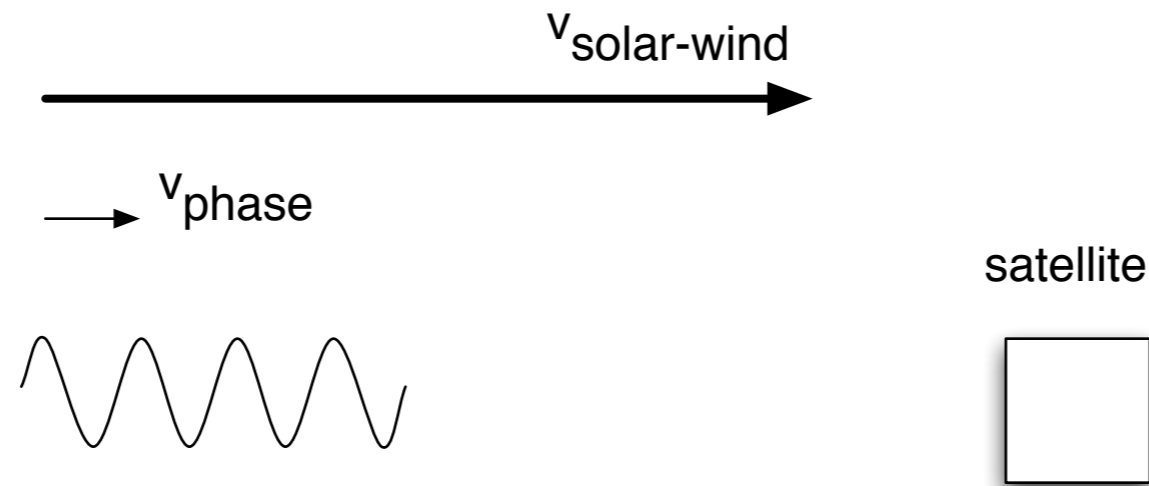

- Near Earth, the speed at which the solar wind flows past a satellite is highly supersonic, typically  $>10v_{\text{phase}}$ , where  $v_{\text{phase}}$  is the phase speed in the plasma rest frame.
- *“Taylor’s Frozen-in Flow Hypothesis”*: Time variation measured by a spacecraft results primarily from the advection of spatially varying quantities past the spacecraft at high speed. The “intrinsic time variation” in the solar-wind frame has almost no effect on the measurements. The spacecraft would see almost the same thing if the fields were static in the solar-wind frame.
- If a wave with wavevector  $\mathbf{k}$  is advected past the spacecraft (i.e.,  $\delta B \propto e^{i\mathbf{k}\cdot\mathbf{x}}$ ), and the wave is static in the solar-wind frame, the spacecraft measures a magnetic oscillation with angular frequency  $\omega = 2\pi f = \mathbf{k}\cdot\mathbf{v}_{\text{solar-wind}}$ .
- Frequencies measured by a spacecraft thus tell us about  $\mathbf{k}$  (spatial structure) rather than the intrinsic time variation that would be seen in the plasma rest frame.

# Taylor's Frozen-in Flow Hypothesis

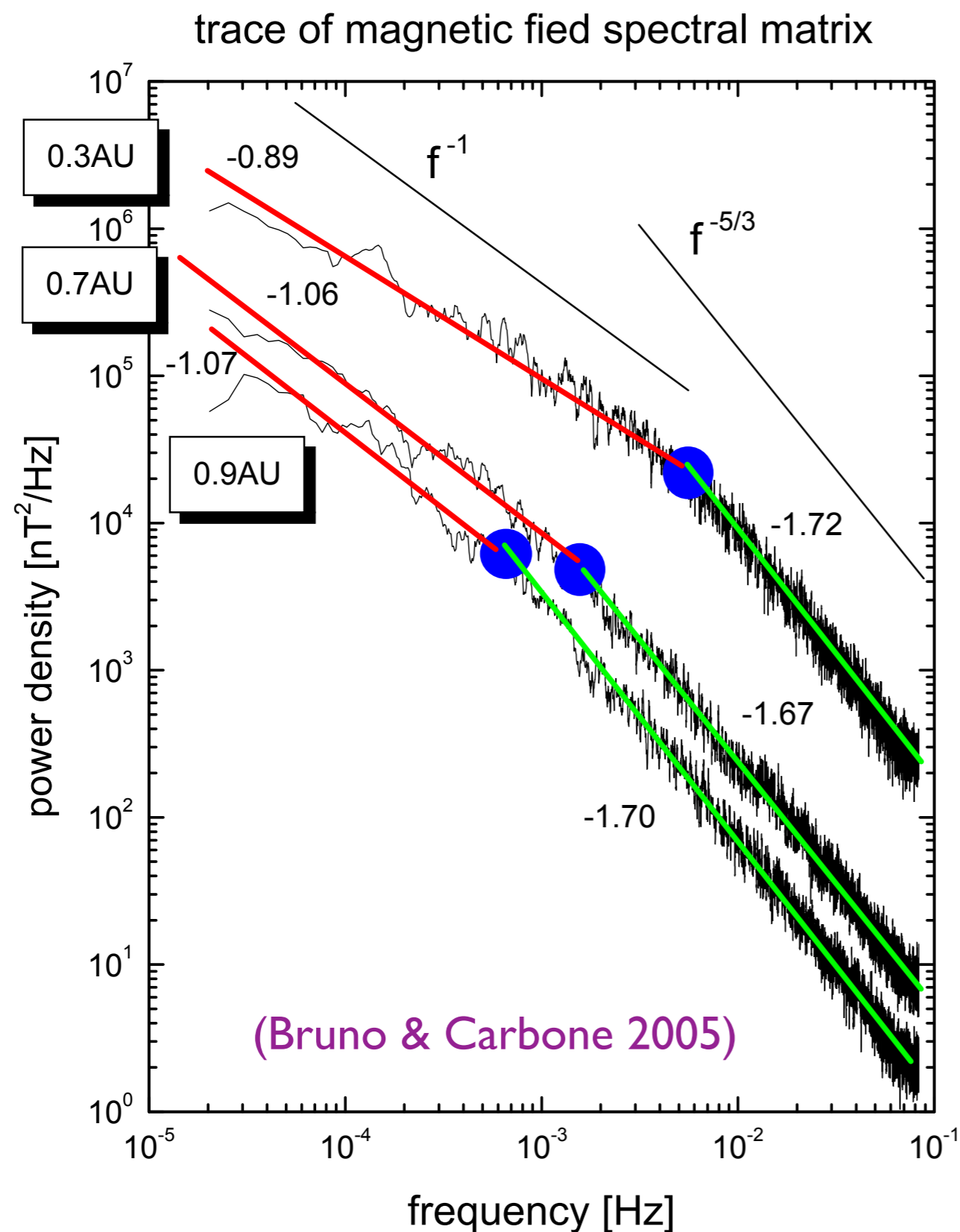

The frequency spectra measured by satellites correspond to wavenumber spectra in the solar-wind frame.

Question: in the data below, the  $v$  and  $B$  fluctuations are highly correlated --- what does this mean? We'll come back to this...

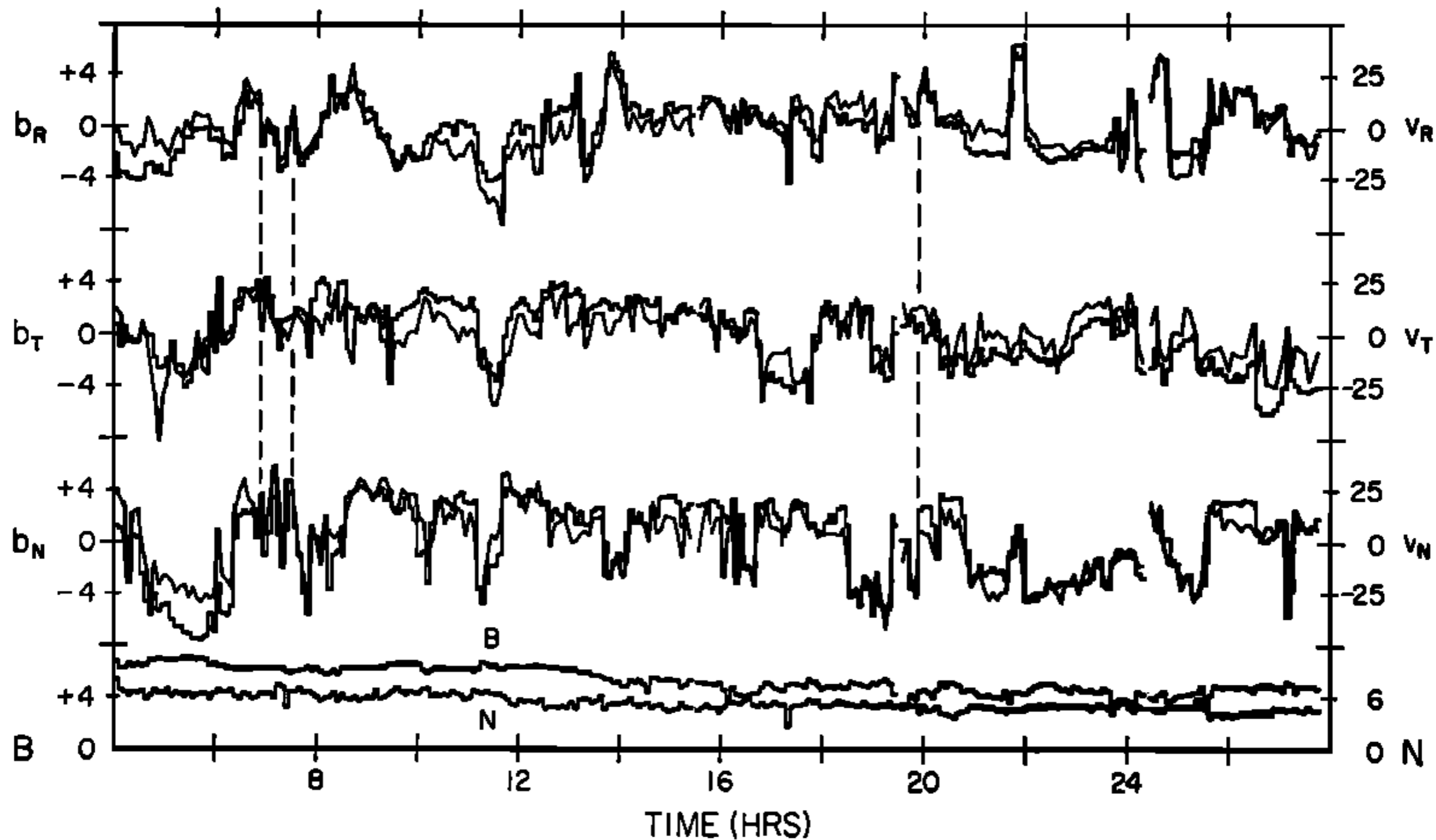

Data from the *Mariner 5* spacecraft (Belcher & Davis 1971)

# Outline

- ✓ I. Introduction to Turbulence
- ✓ II. Measurements of Turbulence in the Solar Wind.
- ⓐ III. Magnetohydrodynamics (MHD)
- IV. Alfvén Waves, the Origin of the Solar Wind, and Solar Probe Plus
- V. Introduction to phenomenological theories of MHD turbulence.

# Magnetohydrodynamics (MHD)

- In order to understand the power spectra seen in the solar wind, we need a theoretical framework for analyzing fluctuations on these lengthscales and timescales.
- In the solar wind near Earth, phenomena occurring at large length scales (exceeding  $\approx 300$  km) and long time scales (e.g., exceeding  $\approx 10$  s) can be usefully described within the framework of a fluid theory called magnetohydrodynamics (MHD).
- In MHD, the plasma is quasi-neutral, and the displacement current is neglected in Maxwell's equations (since the fluctuation frequencies are small).

# Ideal, Adiabatic MHD

density  $\rho$  velocity  $\vec{v}$  magnetic field  $\vec{B}$

$$\frac{\partial \rho}{\partial t} = -\nabla \cdot (\rho \vec{v})$$
$$\rho \left( \frac{\partial \vec{v}}{\partial t} + \vec{v} \cdot \nabla \vec{v} \right) = -\nabla \left( p + \frac{B^2}{8\pi} \right) + \frac{\vec{B} \cdot \nabla \vec{B}}{4\pi}$$

pressure  $p$  ratio of specific heats  $\gamma$

$$\left( \frac{\partial}{\partial t} + \vec{v} \cdot \nabla \right) \left( \frac{p}{\rho^\gamma} \right) = 0$$
$$\frac{\partial \vec{B}}{\partial t} = \nabla \times (\vec{v} \times \vec{B})$$

(The phrase “ideal MHD” means that dissipative terms involving viscosity and resistivity have been neglected. I’ll come back to these terms later.)

# Ideal, Adiabatic MHD

“continuity equation”

$$\frac{\partial \rho}{\partial t} = -\nabla \cdot (\rho \vec{v})$$

mass conservation

$$\rho \left( \frac{\partial \vec{v}}{\partial t} + \vec{v} \cdot \nabla \vec{v} \right) = -\nabla \left( p + \frac{B^2}{8\pi} \right) + \frac{\vec{B} \cdot \nabla \vec{B}}{4\pi}$$

$$\left( \frac{\partial}{\partial t} + \vec{v} \cdot \nabla \right) \left( \frac{p}{\rho^\gamma} \right) = 0$$

$$\frac{\partial \vec{B}}{\partial t} = \nabla \times (\vec{v} \times \vec{B})$$

# Ideal, Adiabatic MHD

Newton's 2nd  
law

$$\frac{\partial \rho}{\partial t} = -\nabla \cdot (\rho \vec{v})$$

$$\rho \left( \frac{\partial \vec{v}}{\partial t} + \vec{v} \cdot \nabla \vec{v} \right) = -\nabla \left( p + \frac{B^2}{8\pi} \right) + \frac{\vec{B} \cdot \nabla \vec{B}}{4\pi}$$

$$\left( \frac{\partial}{\partial t} + \vec{v} \cdot \nabla \right) \left( \frac{p}{\rho^\gamma} \right) = 0$$

$$\frac{\partial \vec{B}}{\partial t} = \nabla \times (\vec{v} \times \vec{B})$$



# Ideal, Adiabatic MHD

$$\frac{\partial \rho}{\partial t} = -\nabla \cdot (\rho \vec{v})$$

$$\rho \left( \frac{\partial \vec{v}}{\partial t} + \vec{v} \cdot \nabla \vec{v} \right) = -\nabla \left( p + \frac{B^2}{8\pi} \right) + \frac{\vec{B} \cdot \nabla \vec{B}}{4\pi}$$

$$\left( \frac{\partial}{\partial t} + \vec{v} \cdot \nabla \right) \left( \frac{p}{\rho^\gamma} \right) = 0$$

adiabatic evolution.  
the specific entropy  
[ $\propto \ln(p/\rho^\gamma)$ ] of a fluid  
element does not  
change in time.

$$\frac{\partial \vec{B}}{\partial t} = \nabla \times (\vec{v} \times \vec{B})$$

(An alternative, simple approximation is the isothermal approximation, in which  $p = \rho c_s^2$ , with the sound speed  $c_s = \text{constant}$ . More generally, this equation is replaced with an energy equation that includes thermal conduction and possibly other heating and cooling mechanisms.)

# Ideal, Adiabatic MHD

$$\frac{\partial \rho}{\partial t} = -\nabla \cdot (\rho \vec{v})$$

$$\rho \left( \frac{\partial \vec{v}}{\partial t} + \vec{v} \cdot \nabla \vec{v} \right) = -\nabla \left( p + \frac{B^2}{8\pi} \right) + \frac{\vec{B} \cdot \nabla \vec{B}}{4\pi}$$

$$\left( \frac{\partial}{\partial t} + \vec{v} \cdot \nabla \right) \left( \frac{p}{\rho^\gamma} \right) = 0$$

$$\frac{\partial \vec{B}}{\partial t} = \nabla \times (\vec{v} \times \vec{B})$$

Ohm's Law for  
a perfectly  
conducting  
plasma

# Ideal, Adiabatic MHD

$$\frac{\partial \rho}{\partial t} = -\nabla \cdot (\rho \vec{v})$$

$$\rho \left( \frac{\partial \vec{v}}{\partial t} + \vec{v} \cdot \nabla \vec{v} \right) = -\nabla \left( p + \frac{B^2}{8\pi} \right) + \frac{\vec{B} \cdot \nabla \vec{B}}{4\pi}$$

$$\left( \frac{\partial}{\partial t} + \vec{v} \cdot \nabla \right) \left( \frac{p}{\rho^\gamma} \right) = 0$$

$$\frac{\partial \vec{B}}{\partial t} = \nabla \times (\vec{v} \times \vec{B})$$

- Magnetic forces: magnetic pressure and magnetic tension
- Frozen-in Law: magnetic field lines are like threads that are frozen to the plasma and advected by the plasma

# Waves: small-amplitude oscillations about some equilibrium

$$\delta \vec{v} = \delta \vec{v}_0 \cos(\vec{k} \cdot \vec{x} - \omega t + \phi_0)$$

wavelength  $\lambda = 2\pi/k$

decreasing  $\lambda \Leftrightarrow$  increasing  $k$

energy cascades to small  $\lambda$ , or equivalently to large  $k$

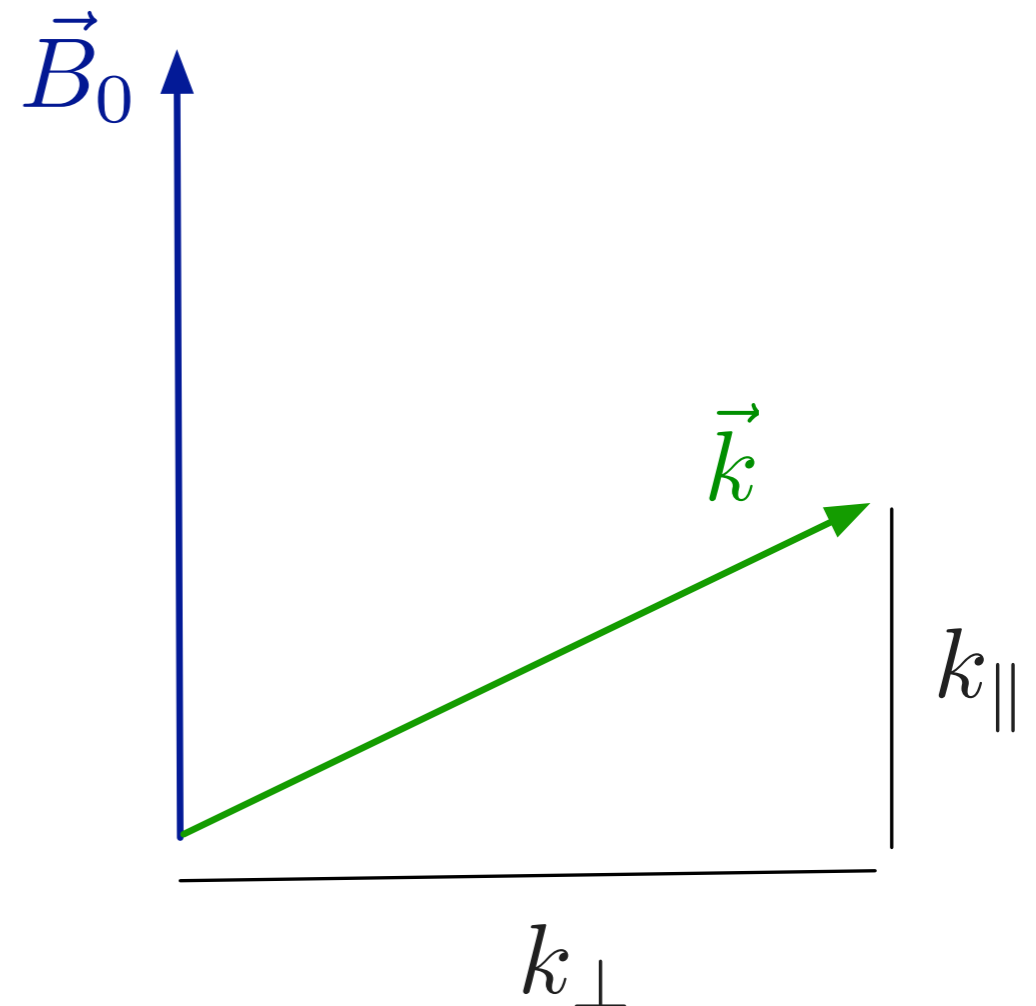

As an example, let's look at MHD Waves in "low-beta" plasmas such as the solar corona.

$$\beta = \frac{8\pi p}{B^2} \ll 1, \quad \text{so magnetic pressure } \frac{B^2}{8\pi} \text{ greatly exceeds } p$$

$$c_s = \text{sound speed} = \sqrt{\frac{\gamma p}{\rho}}$$

$$v_A = \text{"Alfvén speed"} = \frac{B}{\sqrt{4\pi\rho}}$$

$$\longrightarrow \beta = \frac{2c_s^2}{\gamma v_A^2}$$

# Plasma Waves at Low Beta

Alfven wave



magnetic field lines

fast magnetosonic wave

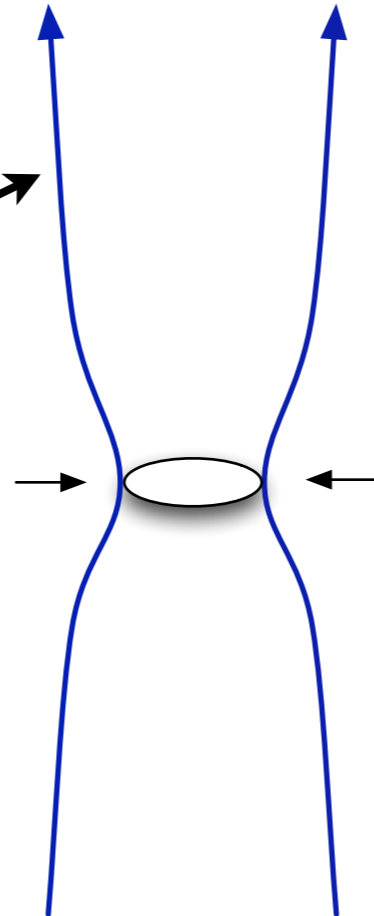

magnetic pressure

slow magnetosonic wave

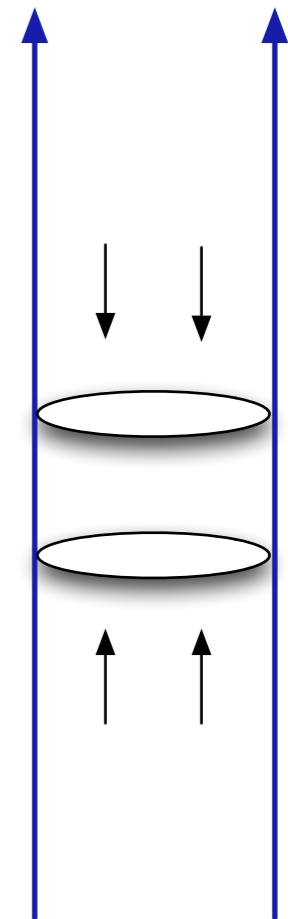

thermal pressure

magnetic tension

(like a wave propagating on a string)

# Plasma Waves at Low Beta

Alfven wave



magnetic tension

$$\omega = k_{\parallel} v_A$$

$$v_A = B / \sqrt{4\pi\rho} \quad \leftarrow \text{“Alfven speed”}$$

fast magnetosonic wave

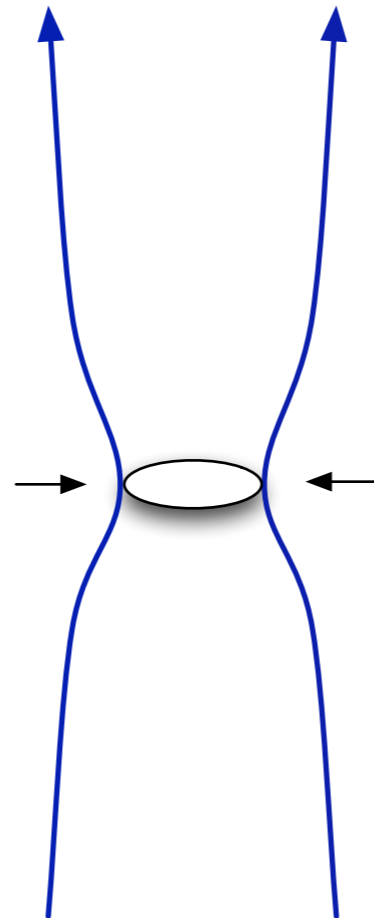

magnetic pressure

slow magnetosonic wave

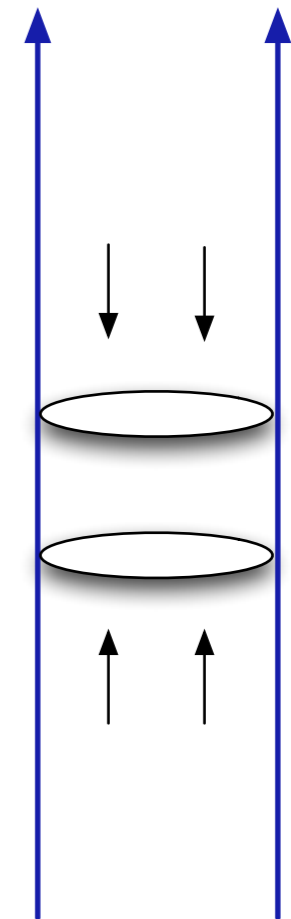

thermal pressure

# Plasma Waves at Low Beta

Alfven wave



magnetic tension

$$\omega = k_{\parallel} v_A$$

$$v_A = B / \sqrt{4\pi\rho}$$

fast magnetosonic wave

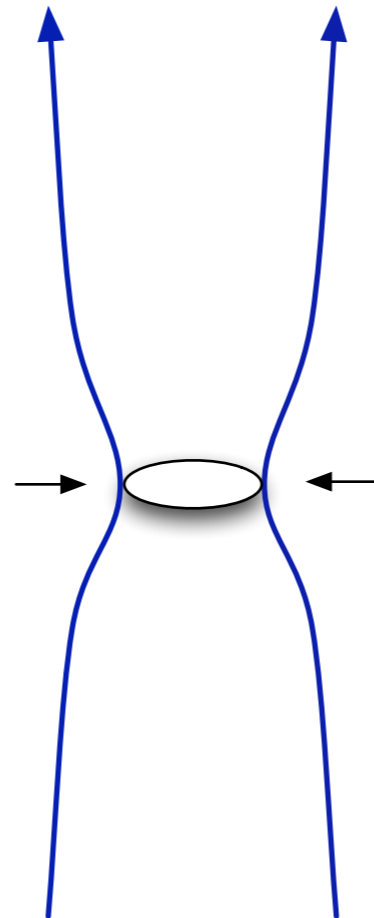

magnetic pressure

$$\omega = kv_A$$

slow magnetosonic wave

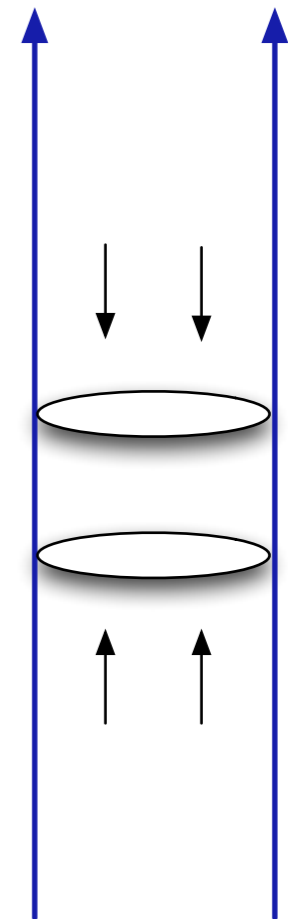

thermal pressure

$$\omega = k_{\parallel} c_s$$

sound speed  $c_s = (\gamma p / \rho)^{1/2}$



# Plasma Waves at Low Beta

Alfven wave



magnetic tension

$$\omega = k_{\parallel} v_A$$

virtually undamped  
in collisionless plasmas  
like the solar wind

fast magnetosonic  
wave

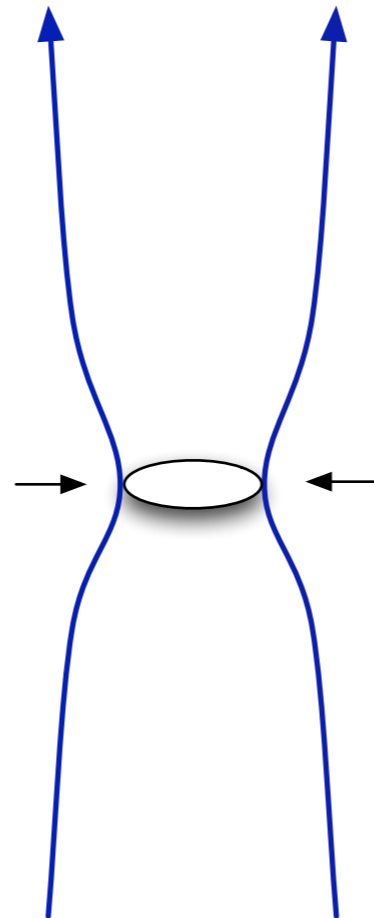

magnetic pressure

$$\omega = k v_A$$

damped in collisionless plasmas  
(weakly at  $\beta \ll 1$ ,  
strongly at  $\beta \approx 1$ )

slow magnetosonic  
wave

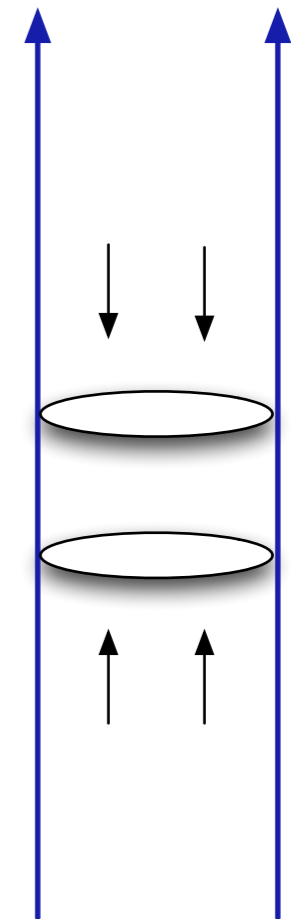

thermal pressure

$$\omega = k_{\parallel} c_s$$

strongly damped  
in collisionless plasmas

# Properties of Alfvén Waves (AWs)

- Two propagation directions: parallel to  $\vec{B}_0$  or anti-parallel to  $\vec{B}_0$ .
- $\delta\vec{v} = \pm\delta\vec{B}/\sqrt{4\pi\rho_0}$  for AWs propagating in the  $\mp\vec{B}_0$  direction, and  $\delta\rho = 0$

# Properties of Alfvén Waves (AWs)

- Two propagation directions: parallel to  $\vec{B}_0$  or anti-parallel to  $\vec{B}_0$ .
- $\delta\vec{v} = \pm\delta\vec{B}/\sqrt{4\pi\rho_0}$  for AWs propagating in the  $\mp\vec{B}_0$  direction, and  $\delta\rho = 0$
- In the solar wind  $\delta\rho/\rho_0 \ll |\delta\vec{B}/B_0|$ . Also, there are many intervals of time in which the relation  $\delta\vec{v} = \pm\delta\vec{B}/\sqrt{4\pi\rho_0}$  is nearly satisfied, with the sign corresponding to propagation of AWs away from the Sun.

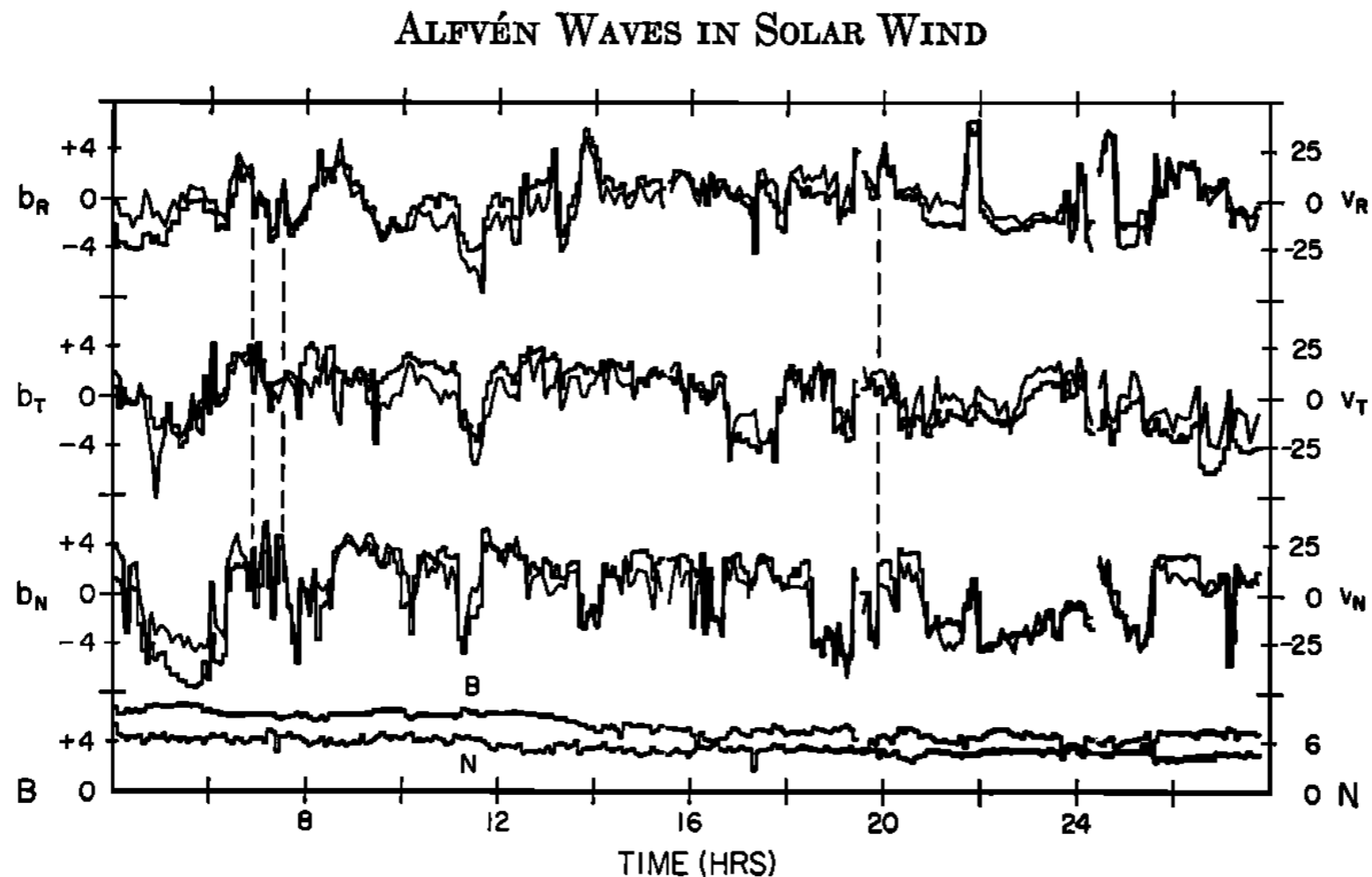

(Belcher & Davis 1971)

# Properties of Alfvén Waves (AWs)

- Two propagation directions: parallel to  $\vec{B}_0$  or anti-parallel to  $\vec{B}_0$ .
- $\delta\vec{v} = \pm\delta\vec{B}/\sqrt{4\pi\rho_0}$  for AWs propagating in the  $\mp\vec{B}_0$  direction, and  $\delta\rho = 0$
- In the solar wind  $\delta\rho/\rho_0 \ll |\delta\vec{B}/B_0|$ . Also, there are many intervals of time in which the relation  $\delta\vec{v} = \pm\delta\vec{B}/\sqrt{4\pi\rho_0}$  is nearly satisfied, with the sign corresponding to propagation of AWs away from the Sun.
- For these reasons, and because AWs are the least damped of the large-scale plasma waves, AWs or nonlinear AW-like fluctuations likely comprise most of the energy in solar wind turbulence

What role do AWs and AW turbulence play in the solar wind?

One possibility: AW turbulence may be one of the primary mechanisms responsible for generating the solar wind. Let's take a closer look at how this might work.

# Outline

- ✓ I. Introduction to Turbulence
- ✓ II. Measurements of Turbulence in the Solar Wind.
- ✓ III. Magnetohydrodynamics (MHD)
- ④ IV. Alfvén Waves, the Origin of the Solar Wind, and Solar Probe Plus
- V. Introduction to phenomenological theories of MHD turbulence.

# Coronal Heating and Solar-Wind Acceleration by Alfvén Waves

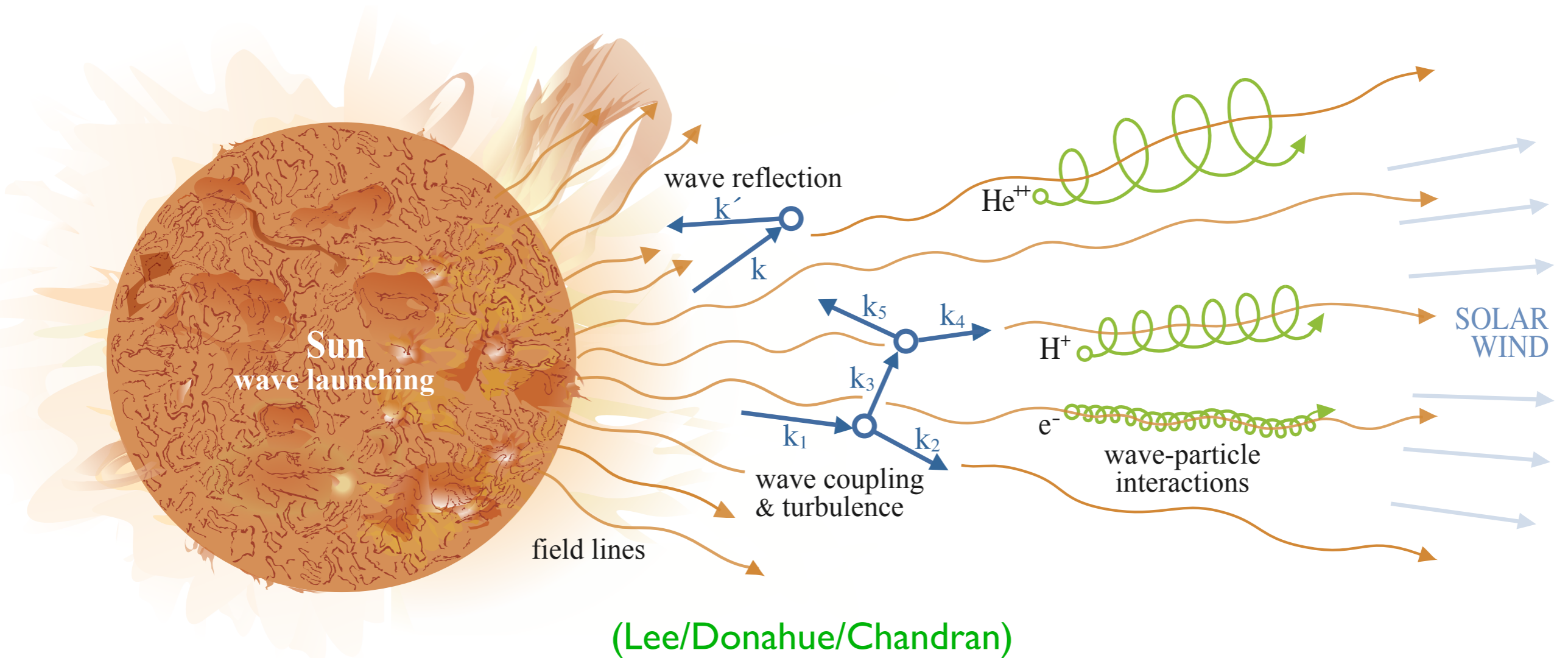

1. Alfvén Waves are launched by the Sun and transport energy outwards
2. The waves become turbulent, which causes wave energy to 'cascade' from long wavelengths to short wavelengths
3. Short-wavelength waves dissipate, heating the corona and launching the solar wind.



# Coronal Heating and Solar-Wind Acceleration by Alfvén Waves

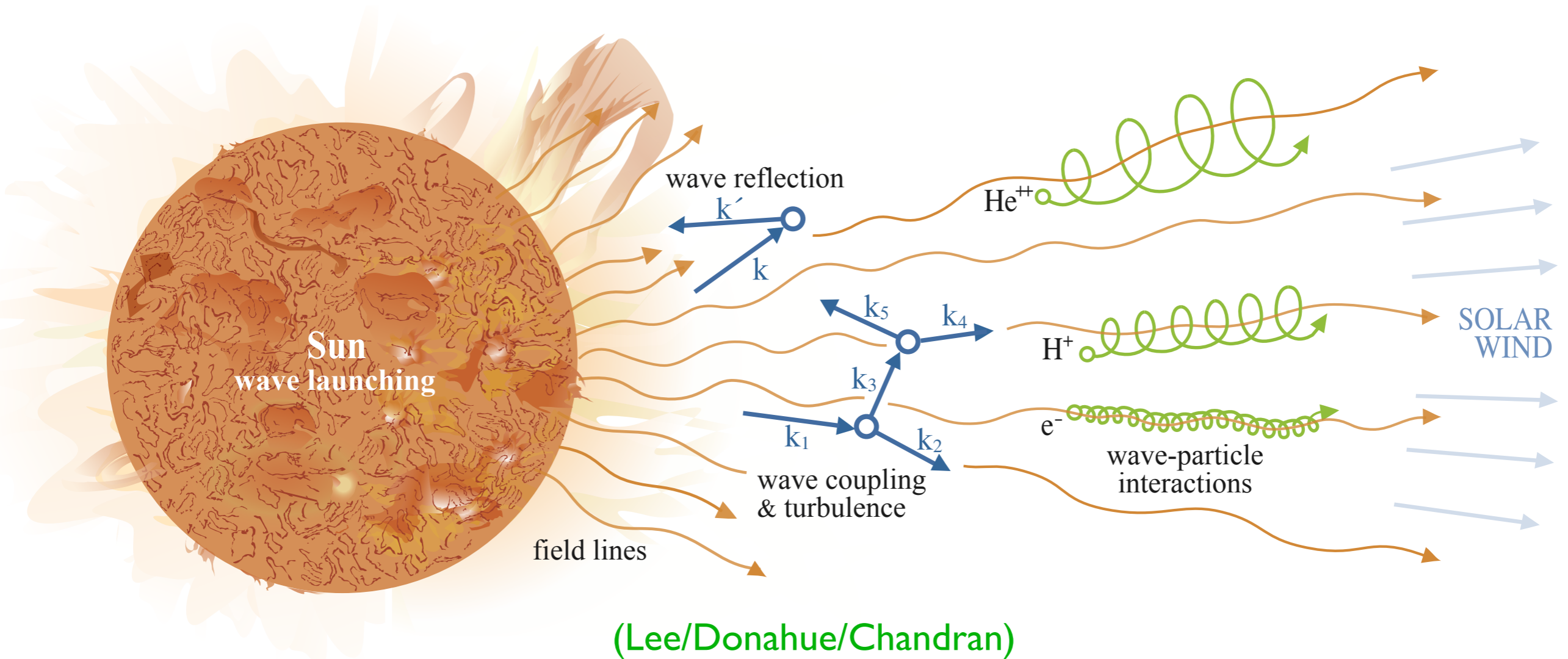

1. Alfvén Waves are launched by the Sun and transport energy outwards
2. The waves become turbulent, which causes wave energy to 'cascade' from long wavelengths to short wavelengths
3. Short-wavelength waves dissipate, heating the corona and launching the solar wind.

# Mechanisms for Launching Waves

1. Magnetic reconnection (e.g., Axford & McKenzie 1992)
2. Motions of the footpoints of coronal magnetic field lines (e.g., Cranmer & van Ballegooijen 2005)



# Alfven Waves in the Chromosphere

(Data from *Hinode* - DePontieu et al 2007)

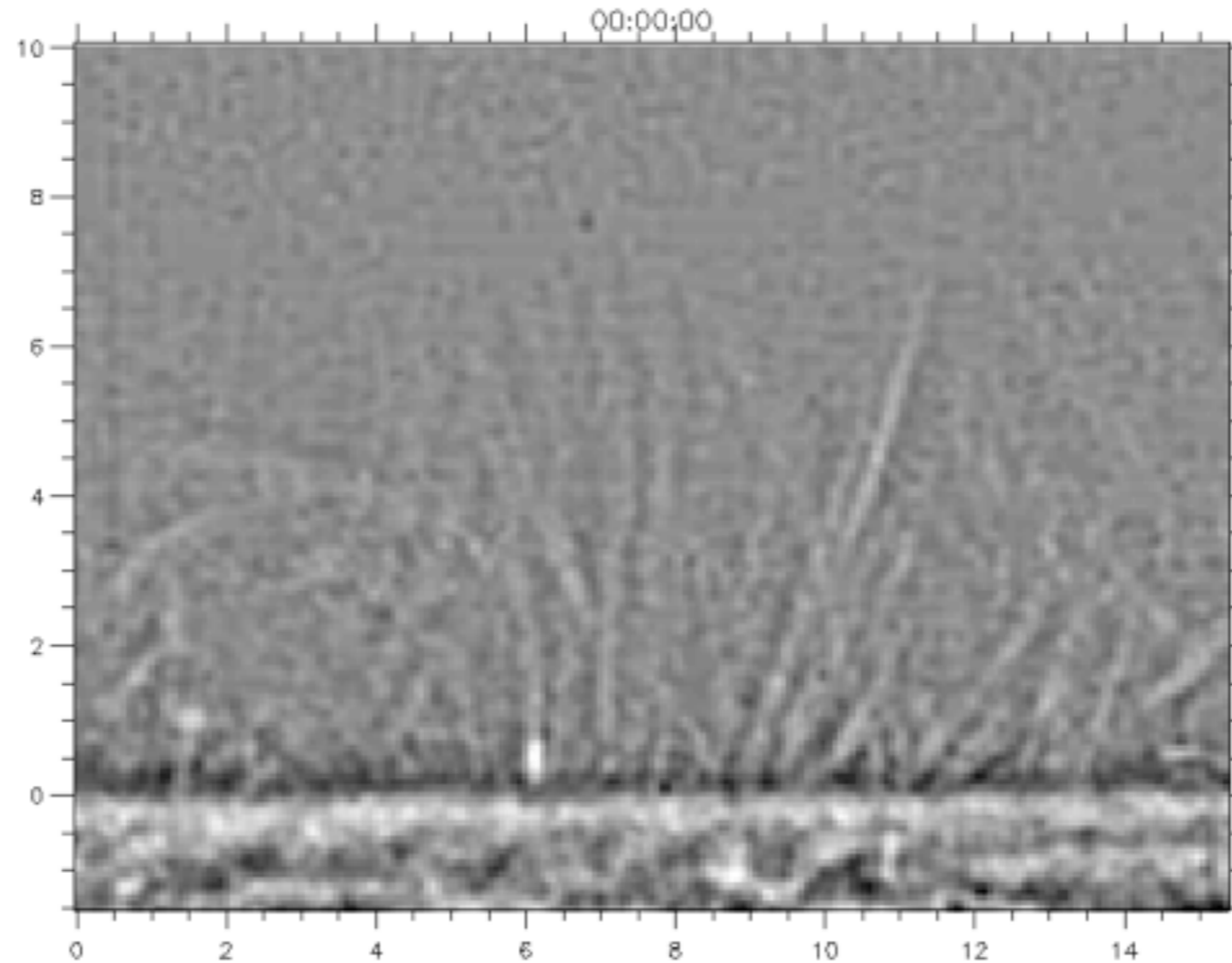

- calculated Alfven-wave energy flux is sufficient to power solar wind
- Alfven waves propagating away from the Sun are also observed in the corona (Tomczyk et al 2007).

# Coronal Heating and Solar-Wind Acceleration by Alfvén Waves

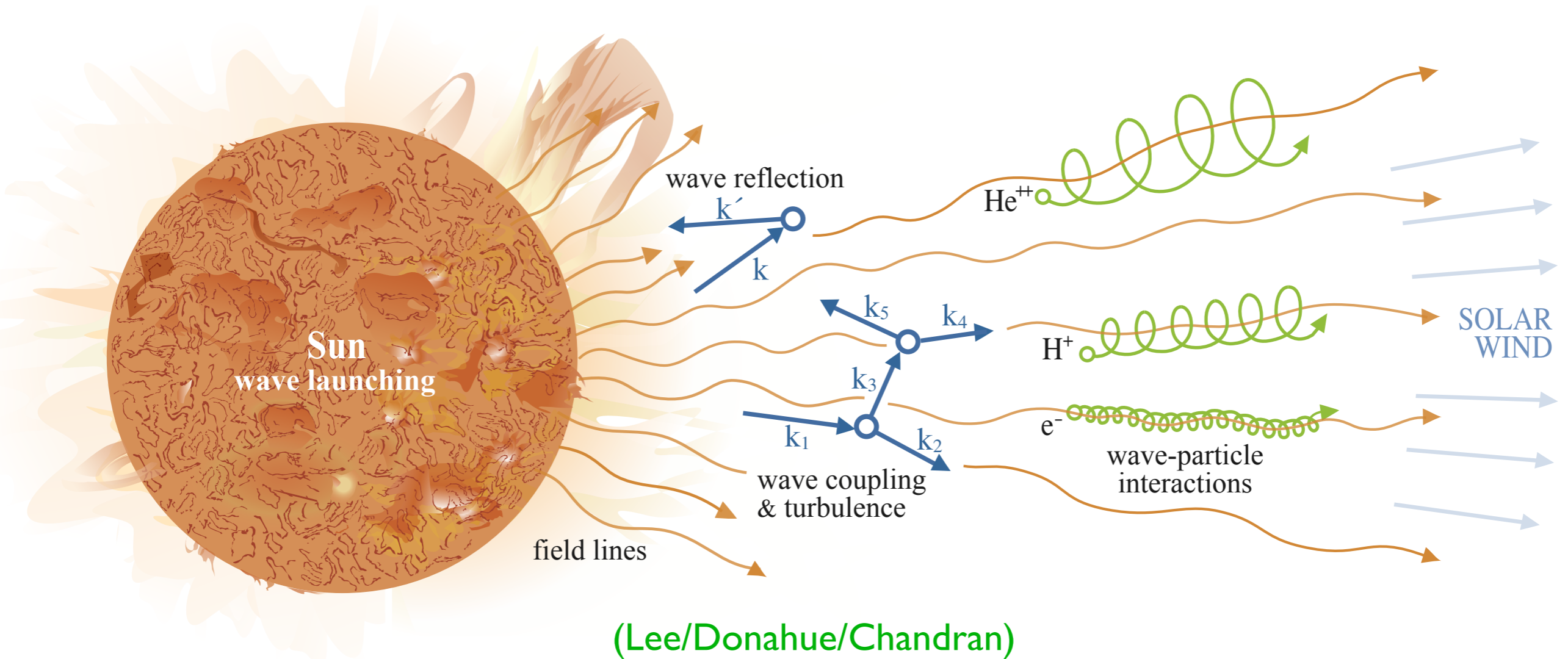

1. Alfvén Waves are launched by the Sun and transport energy outwards
2. The waves become turbulent, which causes wave energy to 'cascade' from long wavelengths to short wavelengths
3. Short-wavelength waves dissipate, heating the corona and launching the solar wind.

# Analogy to Hydrodynamics

Canonical picture: larger eddies break up into smaller eddies

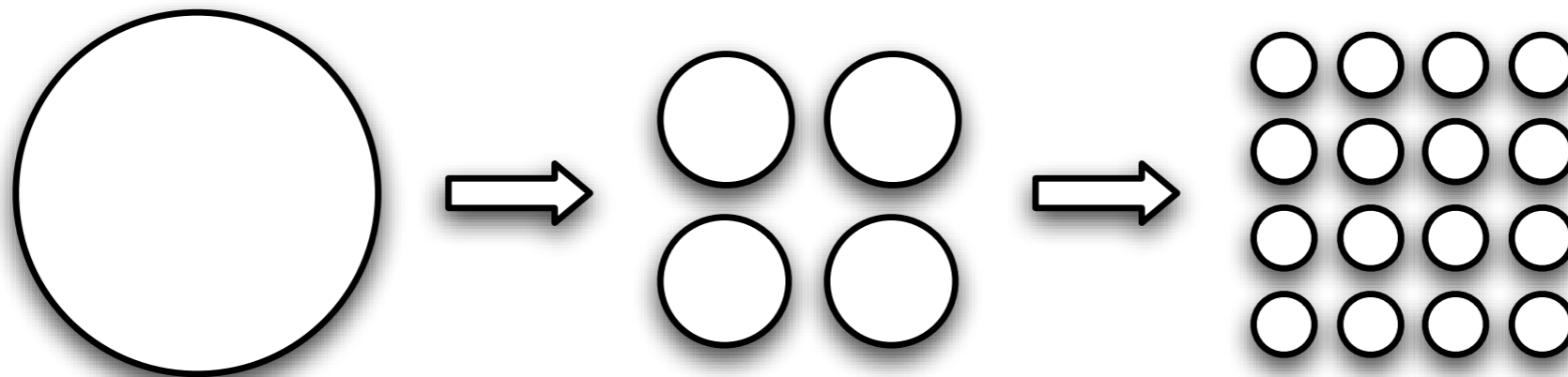

ENERGY  
INPUT

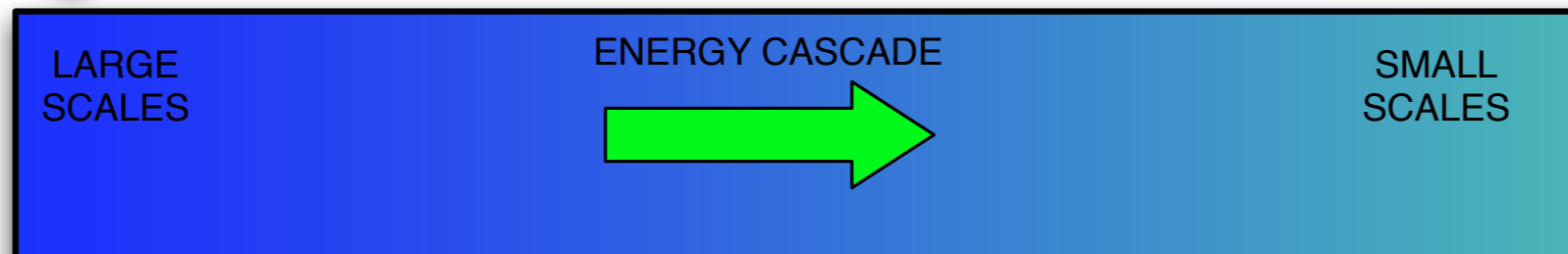
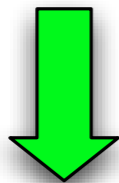

DISSIPATION  
OF FLUCTUATION  
ENERGY

# Coronal Heating and Solar-Wind Acceleration by Alfvén Waves

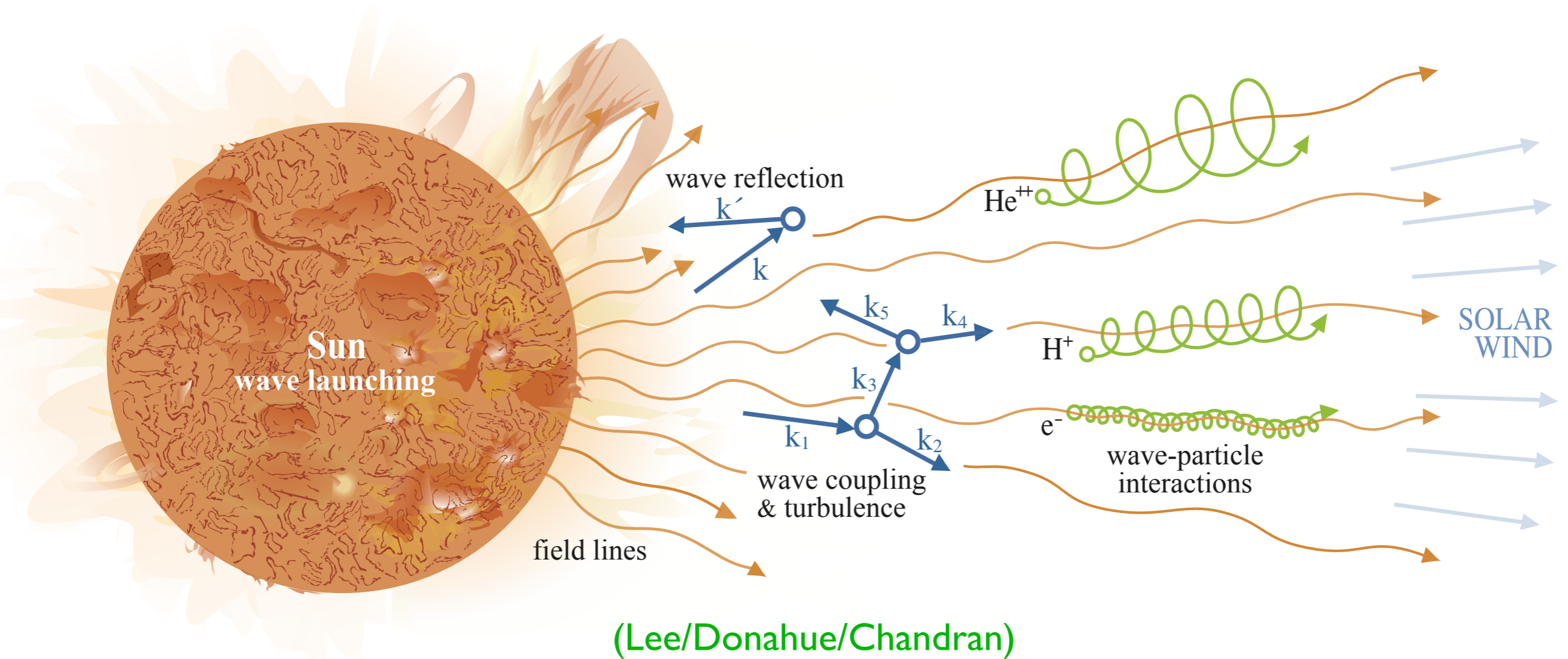

1. Alfvén Waves are launched by the Sun and transport energy outwards
2. The waves become turbulent, which causes wave energy to 'cascade' from long wavelengths to short wavelengths
3. Short-wavelength waves dissipate, heating the corona and launching the solar wind. *Not viscosity, but some type of collisionless dissipation.*

- Farther from the Sun, AW turbulence likely plays an important role in heating the solar wind and determining the solar-wind temperature profile. For reasons of time, I won't go into this in detail. The following references are a starting point for learning more about this: Cranmer et al (2009), Vasquez et al (2007).

Returning to the question of the solar wind's origin, how can we determine if Alfvén-wave turbulence really is responsible for generating the solar wind?



Returning to the question of the solar wind's origin, how can we determine if Alfvén-wave turbulence really is responsible for generating the solar wind?

New frontier in heliospheric physics: in situ measurements of the solar-wind acceleration region...

# *Solar Probe Plus*

1. Several passes to within 10 solar radii of Sun.
2. Planned launch: 2018.
3. In situ measurements will greatly clarify the physics responsible for the solar wind's origin.

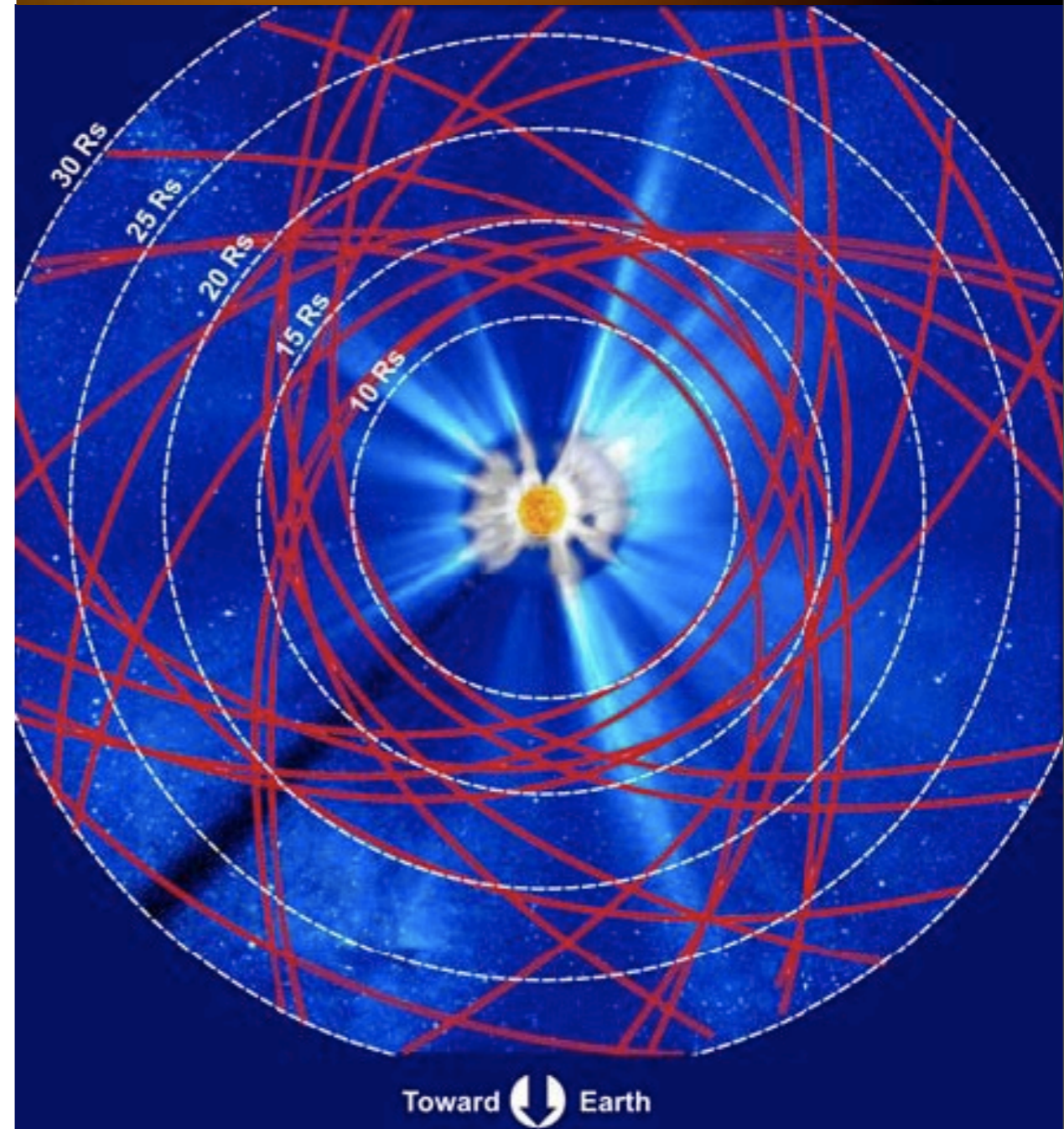
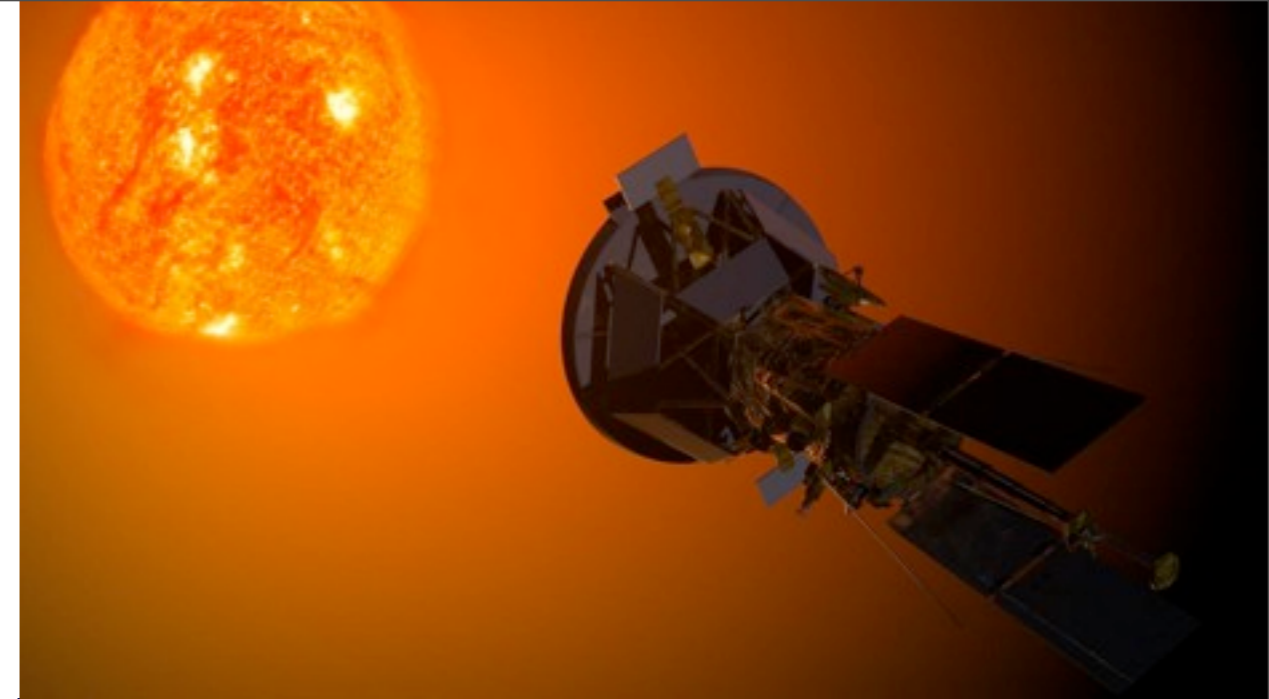



# FIELDS Experiment on *Solar Probe Plus*

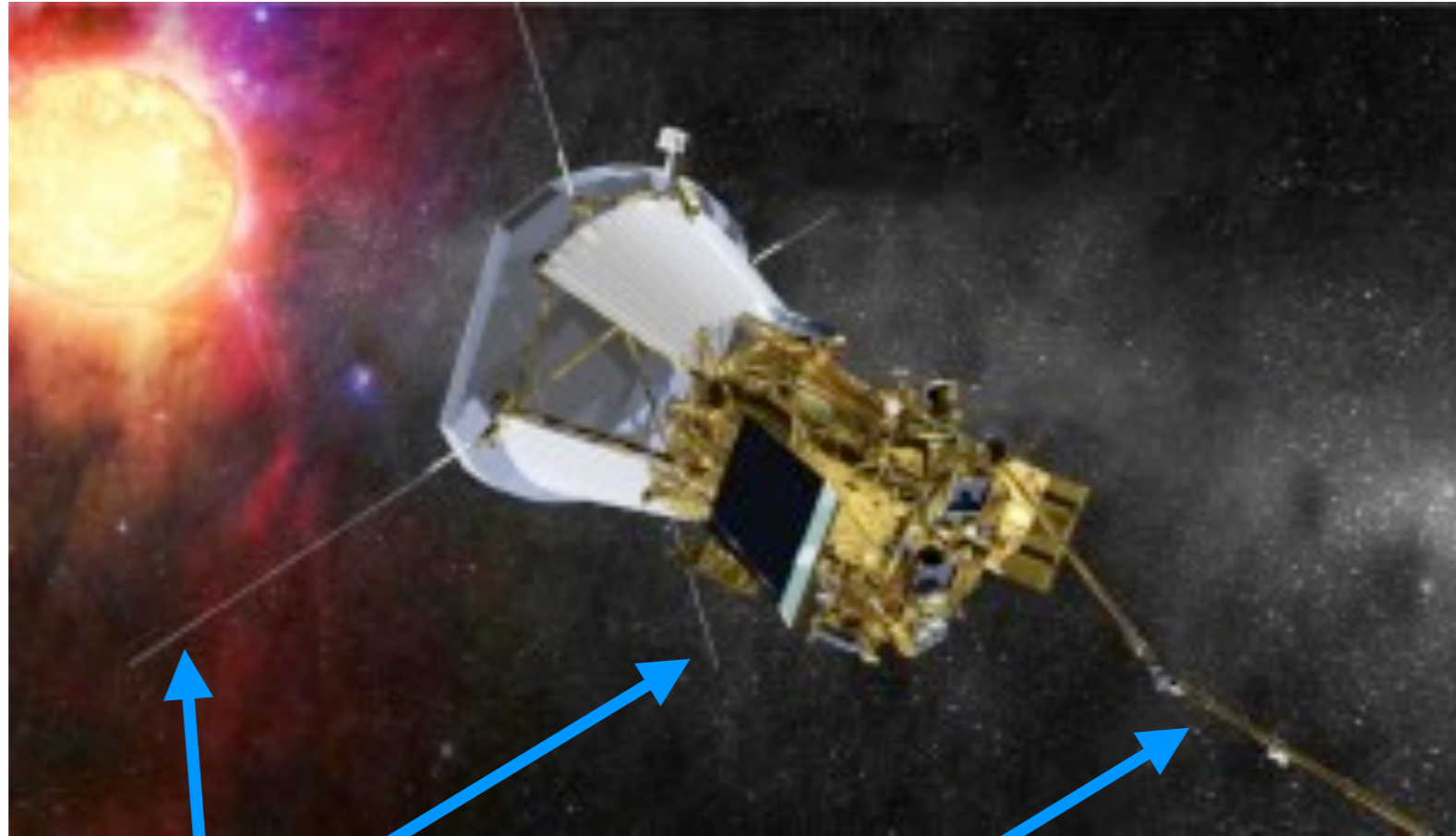

Electric-field antennae

Boom for two flux-gate magnetometers  
and one search-coil magnetometer

FIELDS will provide in-situ measurements of electric fields and magnetic fields in the solar-wind acceleration region

# SWEAP Experiment on *Solar Probe Plus*

**SPC**



**SPAN-B**

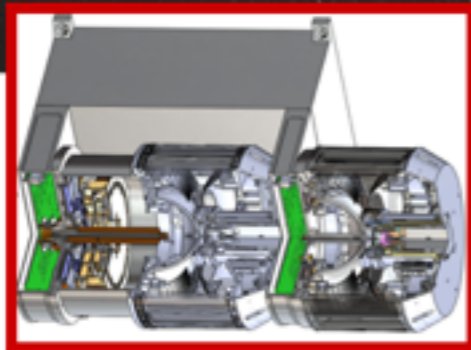
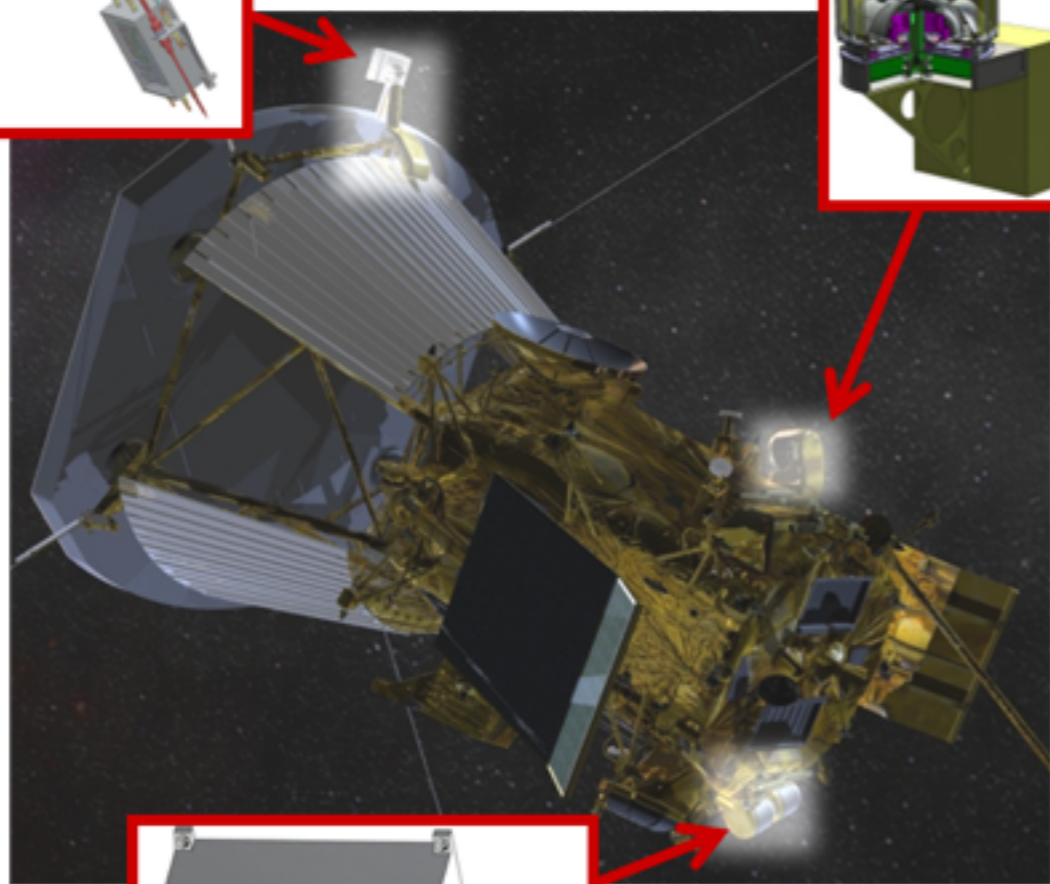
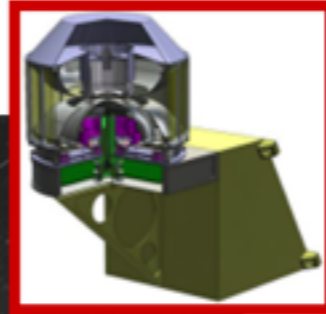

**SPAN-A**

SWEAP will provide in-situ measurements of densities, flow speeds (including velocity fluctuations), and temperatures for electrons, alpha particles, and protons.

# Outline

- ✓ I. Introduction to Turbulence
- ✓ II. Measurements of Turbulence in the Solar Wind.
- ✓ III. Magnetohydrodynamics (MHD)
- ✓ IV. Alfvén Waves, the Origin of the Solar Wind, and Solar Probe Plus
- V. Introduction to phenomenological theories of MHD turbulence.

As discussed previously, Alfvén-wave turbulence likely comprises the bulk of the energy in solar-wind turbulence.

Rather than investigating the full MHD equations, let's work with a limit of the full MHD equations that captures the physics of non-compressive Alfvén waves but neglects compressive motions.

# Incompressible MHD

$$\rho \left( \frac{\partial \vec{v}}{\partial t} + \vec{v} \cdot \nabla \vec{v} \right) = -\nabla \left( p + \frac{B^2}{8\pi} \right) + \frac{1}{4\pi} \vec{B} \cdot \nabla \vec{B} + \rho \nu \nabla^2 \vec{v}$$

$$\frac{\partial \vec{B}}{\partial t} = \nabla \times (\vec{v} \times \vec{B}) + \eta \nabla^2 \vec{B}$$

$$\nabla \cdot \vec{v} = 0$$

$$\rho = \text{constant}$$

kinematic  
viscosity

resistivity

Because Alfvén waves (AWs) satisfy  $\nabla \cdot \mathbf{v} = 0$ , incompressible MHD captures much of the physics of both small-amplitude AWs and AW turbulence.

Because the viscous and resistive terms contain  $\nabla^2$  they dominate for fluctuations with sufficiently small lengthscales.

Elsässer Variables,  $\vec{a}^\pm$

$$\vec{B} = B_0 \hat{z} + \delta \vec{B} \quad (B_0 = \text{constant})$$

$$v_A = B_0 / \sqrt{4\pi\rho}$$

$$\vec{b} = \delta \vec{B} / \sqrt{4\pi\rho}$$

represent AWs traveling  
parallel ( $a^-$ ) or  
anti-parallel ( $a^+$ ) to  $\vec{B}_0$

$$\Pi = \frac{1}{\rho} \left( p + \frac{B^2}{8\pi} \right)$$

$$\vec{a}^\pm = \vec{v} \pm \vec{b}$$

Substitute the above into the MHD eqns and obtain

$$\frac{\partial \vec{a}^\pm}{\partial t} \mp v_A \frac{\partial \vec{a}^\pm}{\partial z} = -\nabla \Pi - \vec{a}^\mp \cdot \nabla \vec{a}^\pm + \{ \text{terms } \propto \text{ to } \nu \text{ or } \eta \}$$

# Conserved Quantities in Ideal, Incompressible MHD

$$\mathcal{E} = \int d^3x \left( \frac{\rho |\vec{v}|^2}{2} + \frac{|\delta \vec{B}|^2}{8\pi} \right) = \frac{\rho}{4} \int d^3x (|\vec{a}^+|^2 + |\vec{a}^-|^2) \quad \leftarrow \text{energy}$$

$$H_m = \int d^3x \vec{A} \cdot \vec{B} \quad \leftarrow \text{magnetic helicity}$$

cross helicity

$$H_c = \int d^3x \vec{v} \cdot \vec{B} = \int d^3x \vec{v} \cdot \vec{B}_0 + \frac{\sqrt{\pi\rho}}{2} \int d^3x (|\vec{a}^+|^2 - |\vec{a}^-|^2)$$

integral vanishes when there is no average flow along  $B_0$

integral measures the difference in energy between AWs moving parallel and anti-parallel to  $B_0$ .

- These “quadratic invariants” are conserved in the “ideal” limit, in which the viscosity and resistivity are set to zero.



# Conserved Quantities and Cascades

- MHD turbulence results from “nonlinear interactions” between fluctuations. These interactions are described mathematically by the nonlinear terms in the MHD equations (e.g.,  $\mathbf{z}^- \cdot \nabla \mathbf{z}^+$ ). When you neglect viscosity and resistivity, the equations conserve  $E$ ,  $H_m$ , and  $H_c$ . The nonlinear terms in the equations thus can’t create or destroy  $E$ ,  $H_m$ , and  $H_c$ , but they can “transport” these quantities from large scales to small scales (a “*forward cascade*”) or from small scales to large scales (an “*inverse cascade*”).
- At sufficiently small scales, dissipation (via viscosity, resistivity, or collisionless wave-particle interactions) truncates a forward energy cascade, leading to turbulent heating of the ambient medium.



# Forward and “Inverse” Cascades in 3D Incompressible MHD

(Frisch et al 1975)

- Energy cascades from large scales to small scales. (Large wave packets or eddies break up into smaller wave packets or eddies.)
- Magnetic helicity cascades from small scales to large scales. (Helical motions associated with rotation cause the growth of large-scale magnetic fields, i.e., dynamos.)

# The Inertial Range of Turbulence

- Suppose turbulence is stirred/excited at a large scale or “outer scale”  $L$ .
- Suppose that the turbulence dissipates at a much smaller scale  $d$ , the “dissipation scale.”
- Lengthscales  $\lambda$  satisfying the inequality  $d \ll \lambda \ll L$  are said to be in the “inertial range” of scales.
- Fluctuations with wavelengths in the inertial range are insensitive to the details of either the forcing at large scales or the dissipation at small scales.
- Systems with different types of large-scale forcing or small-scale dissipation may nevertheless possess similar dynamics and statistical properties in the inertial range (“universality”).

# Kolmogorov's Theory of Inertial-Range Scalings in Hydrodynamic Turbulence

$\delta v_\lambda$  = rms amplitude of velocity difference  
across a spatial separation  $\lambda$

$\tau_c$  = “cascade time”

$\tau_c \sim \lambda / (\delta v_\lambda) =$  “eddy turnover time” 

$\epsilon \sim (\delta v_\lambda)^2 / \tau_c =$  “cascade power”

$$\epsilon \sim (\delta v_\lambda)^3 / \lambda$$

In the “inertial range,”  $\epsilon$  is independent of  $\lambda$ .

$$\longrightarrow \delta v_\lambda \propto \lambda^{1/3}$$

The shearing/  
cascading of eddies  
of size  $\lambda$  is dominated  
by eddies of similar  
size: interactions are  
“local” in scale.

# “Energy Cascade” in Hydrodynamic Turbulence

Canonical picture: larger eddies break up into smaller eddies

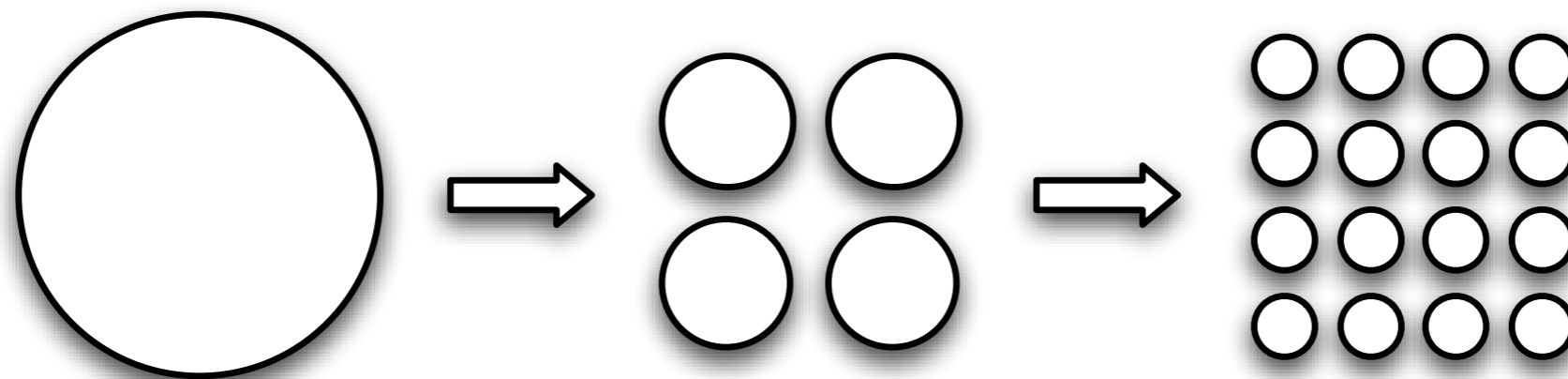

ENERGY  
INPUT

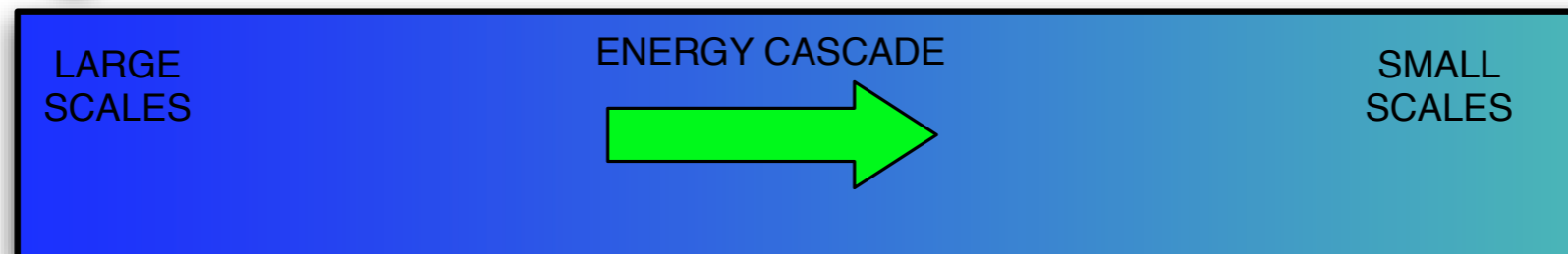
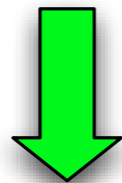

A thick green arrow pointing downwards from the 'SMALL SCALES' section of the energy cascade diagram to the text 'DISSIPATION OF FLUCTUATION ENERGY'.

DISSIPATION  
OF FLUCTUATION  
ENERGY

# Connection to Power Spectra

- Let  $f = kv_{\text{solar-wind}}/2\pi$ , and  $E(k)dk = P(f)df$ , where  $P(f)$  (or  $E(k)$ ) is the frequency (or wavenumber) power spectrum of the *velocity* fluctuations. (This velocity power spectrum is defined just like the magnetic power spectrum introduced earlier in the talk, but with  $\vec{B} \rightarrow \vec{v}$ .)
- The total kinetic energy in velocity fluctuations per unit mass is  $0.5 \int_0^\infty E(k)dk$ .
- The mean square velocity fluctuation at lengthscale  $\lambda \equiv k_1^{-1}$  is given by

$$(\delta v_\lambda)^2 \simeq \int_{0.5k_1}^{2k_1} E(k) dk \sim k_1 E(k_1)$$

- If  $\delta v_\lambda \propto \lambda^{1/3} \propto k_1^{-1/3}$ , then  $E(k) \propto k^{-5/3}$ , and

$$P(f) \propto f^{-5/3}.$$

- We saw earlier in this talk that this type of scaling is seen in magnetic-field measurements. A similar scaling is also seen in velocity fluctuation measurements, although the exponent appears to be somewhat smaller than 5/3 (Podesta et al 2007).

# Alfven-Wave Turbulence

- Wave propagation adds an additional complication.
- Here, I'm going to walk you through some difficult physics, and try to convey some important ideas through diagrams rather than equations.
- These ideas are useful and have been influential in the field, but represent a highly idealized viewpoint that misses some physics and is not universally accepted.
- This is challenging material the first time you see it, but these notes will hopefully serve as a useful introduction, and one that you can build upon with further study if you wish to learn more.

## Nonlinear terms - the basis of turbulence

No nonlinear terms  $\rightarrow$  linear waves. Small nonlinear terms  $\rightarrow$  fluctuations are still wavelike, but waves interact (“weak turbulence” or “wave turbulence”). Large nonlinear terms  $\rightarrow$  strong turbulence, fluctuations are no longer wave-like.

$$\frac{\partial \vec{a}^{\pm}}{\partial t} \mp v_A \frac{\partial \vec{a}^{\pm}}{\partial z} = -\nabla \Pi - \vec{a}^{\mp} \cdot \nabla \vec{a}^{\pm}$$

Note that the nonlinear terms vanish unless  $a^+$  and  $a^-$  are both nonzero. Nonlinear interactions result from “collisions between oppositely directed wave packets” (Iroshnikov 1963, Kraichnan 1965).

$$\frac{\partial \vec{a}^-}{\partial t} + (v_A \hat{z} + \vec{a}^+) \cdot \nabla \vec{a}^- = -\nabla \Pi$$

If  $\vec{a}^+ = 0$ , the  $\vec{a}^-$  waves follow the background field  $B_0 \hat{z}$ . When  $\vec{a}^+ \neq 0$  and  $a^+ \ll v_A$ , the  $\vec{a}^-$  waves approximately follow the field lines corresponding to  $B_0 \hat{z}$  and the part of  $\delta \vec{B}$  associated with the  $\vec{a}^+$  waves (Maron & Goldreich 2001).

**the way that wave packets displace field lines is the key to understanding nonlinear wave-wave interactions**

An Alfvén Wave Packet in 1D

Alfvén wave packet,  
with  $\delta B \perp B_0$

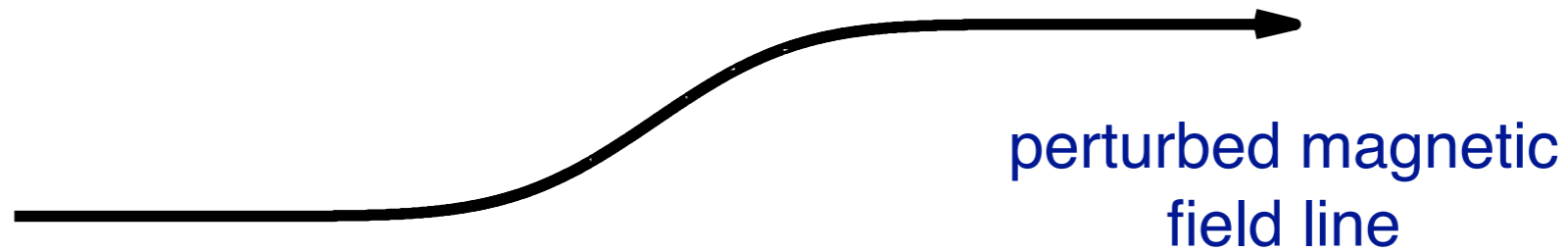
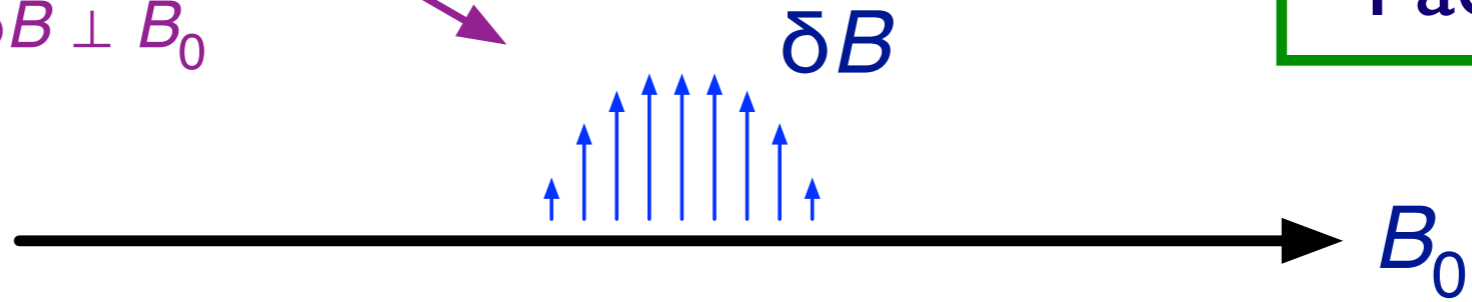

if  $v = -b = -\delta B / (4\pi\rho)^{1/2}$ , it is an  $a^-$  wave packet that moves to the right

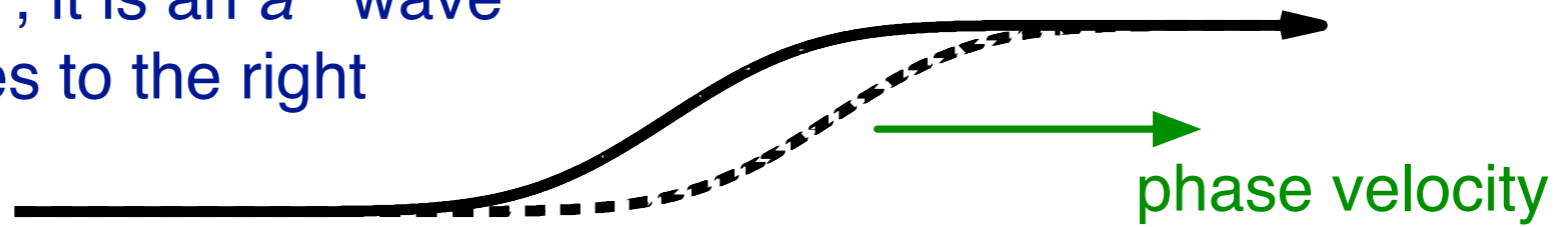

An “incoming”  $a^+$  wave packet from the right would follow the perturbed field line, moving to the left and down.



An Alfvén Wave Packet in 3D

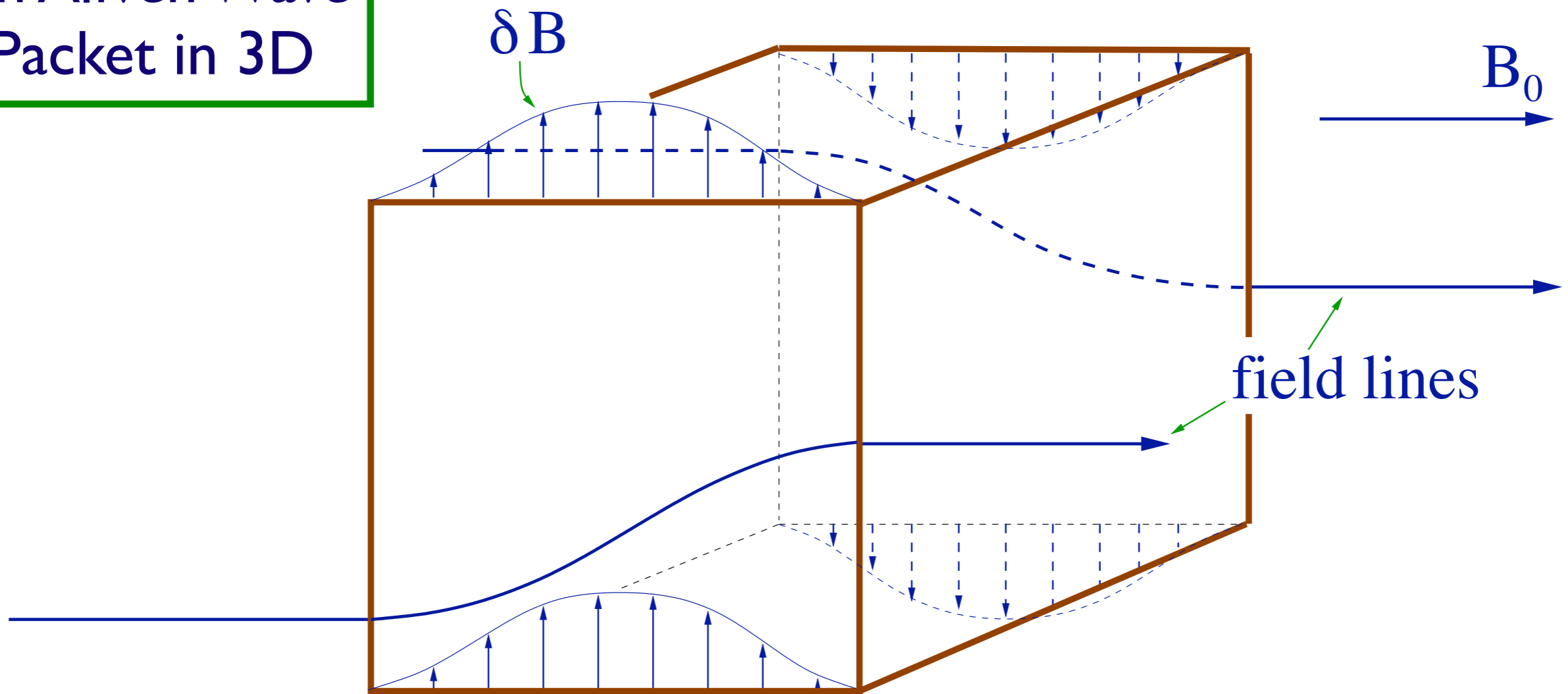

If  $\vec{v} = -\vec{b}$ , then  $a^+ = 0$  and this is an  $a^-$  wave packet that propagates to the right without distortion.

An "incoming"  $a^+$  wave packet approaching from the right would follow the perturbed field lines, moving left and down in the plane of the cube nearest to you and moving to the left and up in the plane of the cube farthest from you.

BEFORE COLLISION:

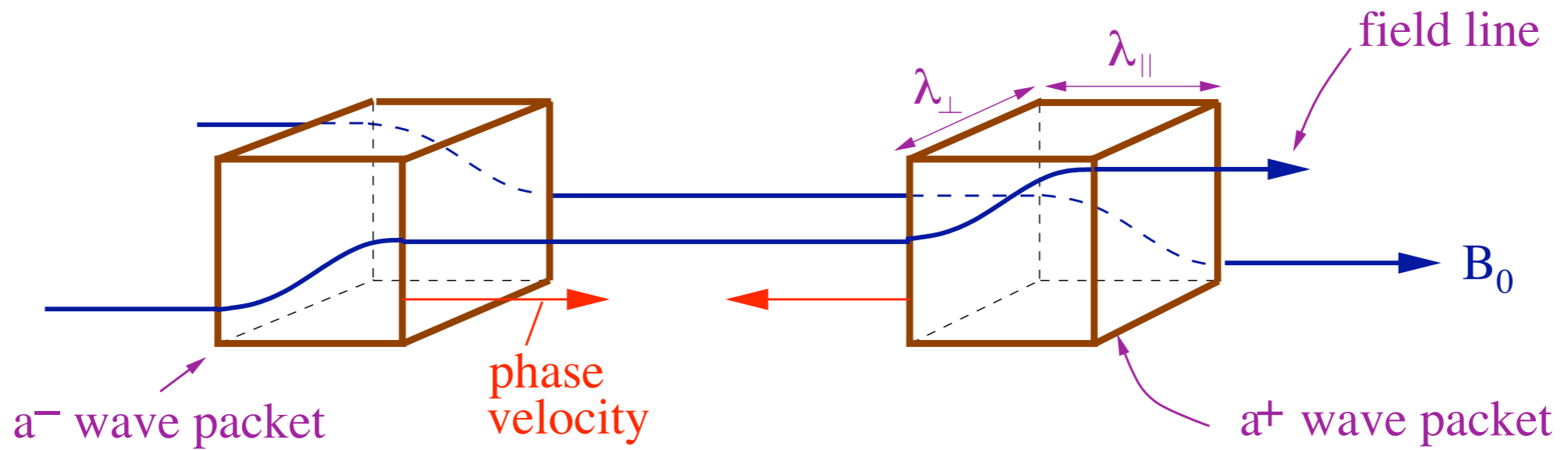

DURING COLLISION: each wave packet follows the field lines of the other wave packet

AFTER COLLISION: wave packets have passed through each other and have been sheared

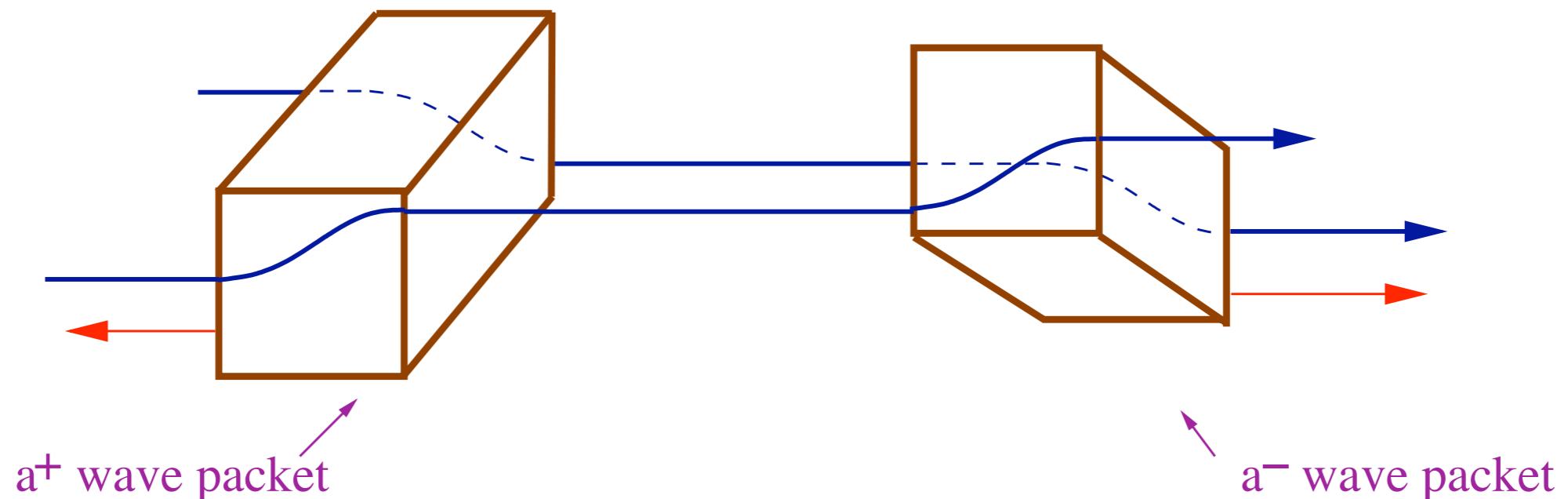

# Shearing of a wave packet by field-line wandering

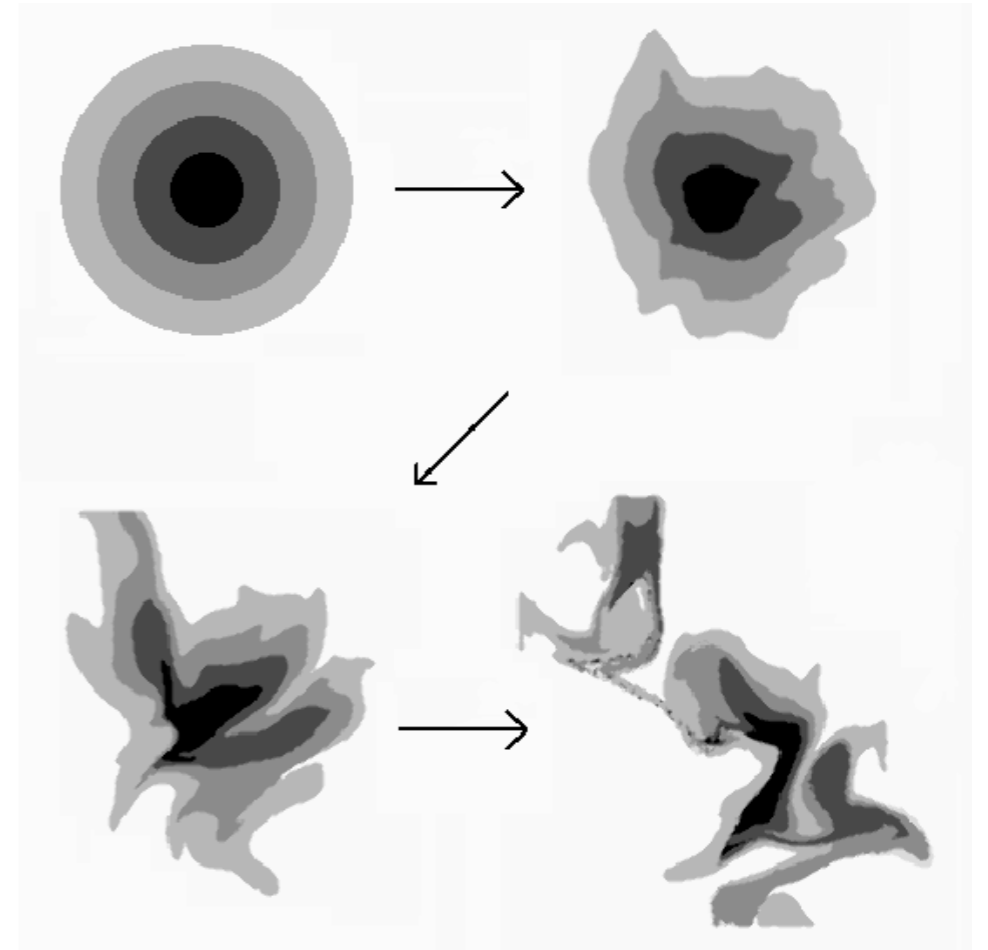

Maron & Goldreich (2001)

# Anisotropic energy cascade

BEFORE COLLISION:

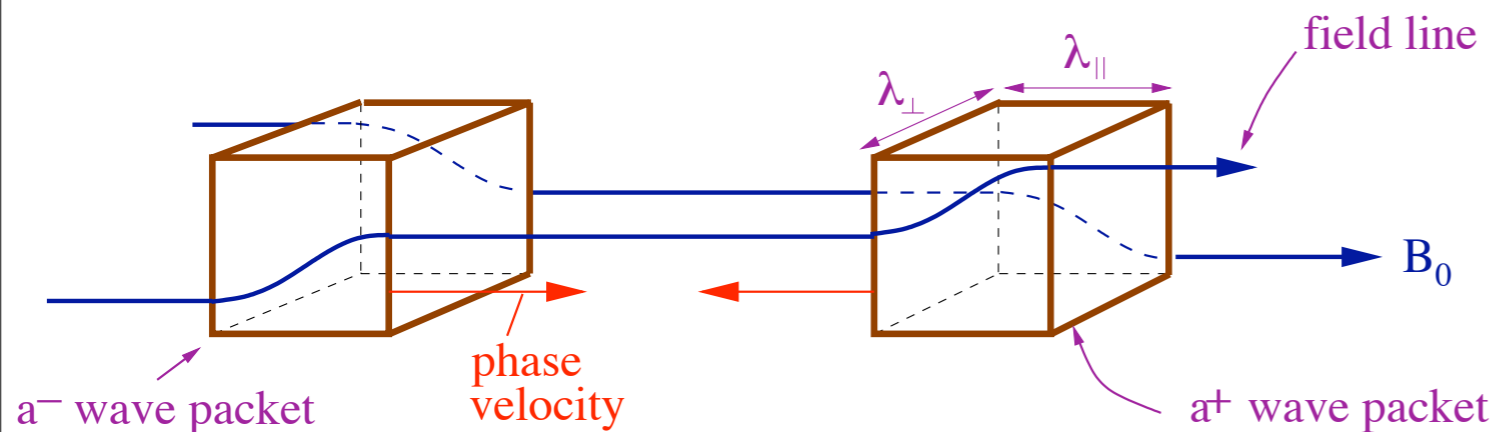

DURING COLLISION: each wave packet follows the field lines of the other wave packet

AFTER COLLISION: wave packets have passed through each other and have been sheared

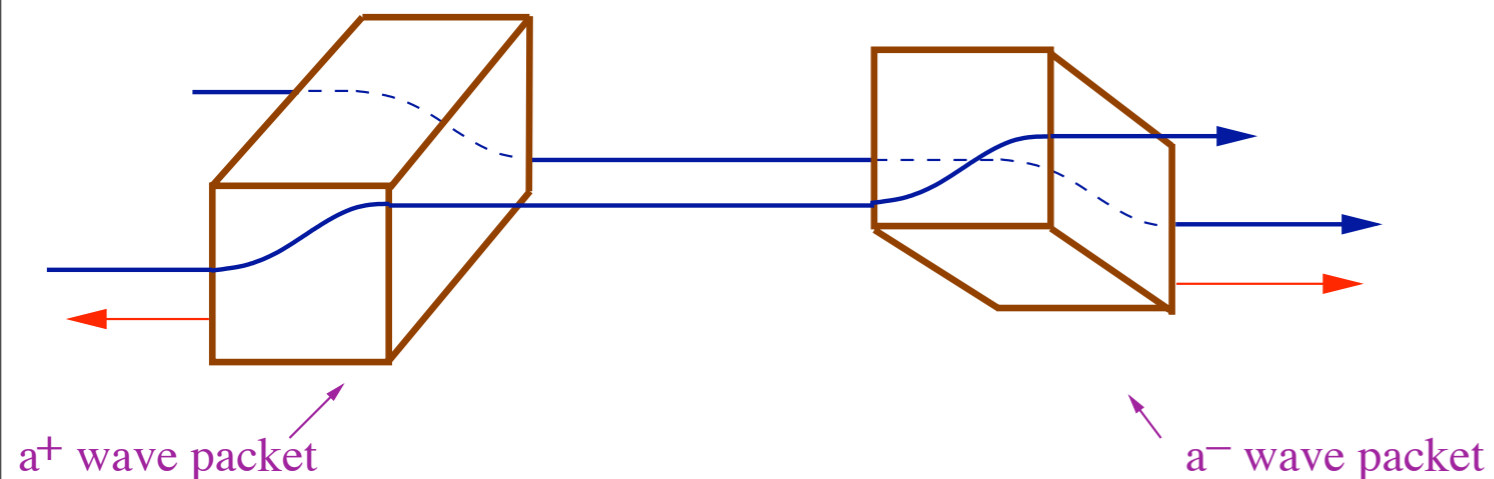

In *weak* turbulence, neither wave packet is changed appreciably during a single “collision,” so, e.g., the right and left sides the “incoming”  $a^+$  wave packet are affected in almost exactly the same way by the collision. This means that the structure of the wave packet along the field line is altered only very weakly (at 2nd order). You thus get small-scale structure transverse to the magnetic field, but not along the magnetic field. (Large perpendicular wave numbers, not large parallel wave numbers.) (Shebalin, Matthaeus, & Montgomery 1983, Ng & Bhattacharjee 1997, Goldreich & Sridhar 1997)

# Anisotropic Cascade

(Shebalin, Montgomery, & Matthaeus 1983)

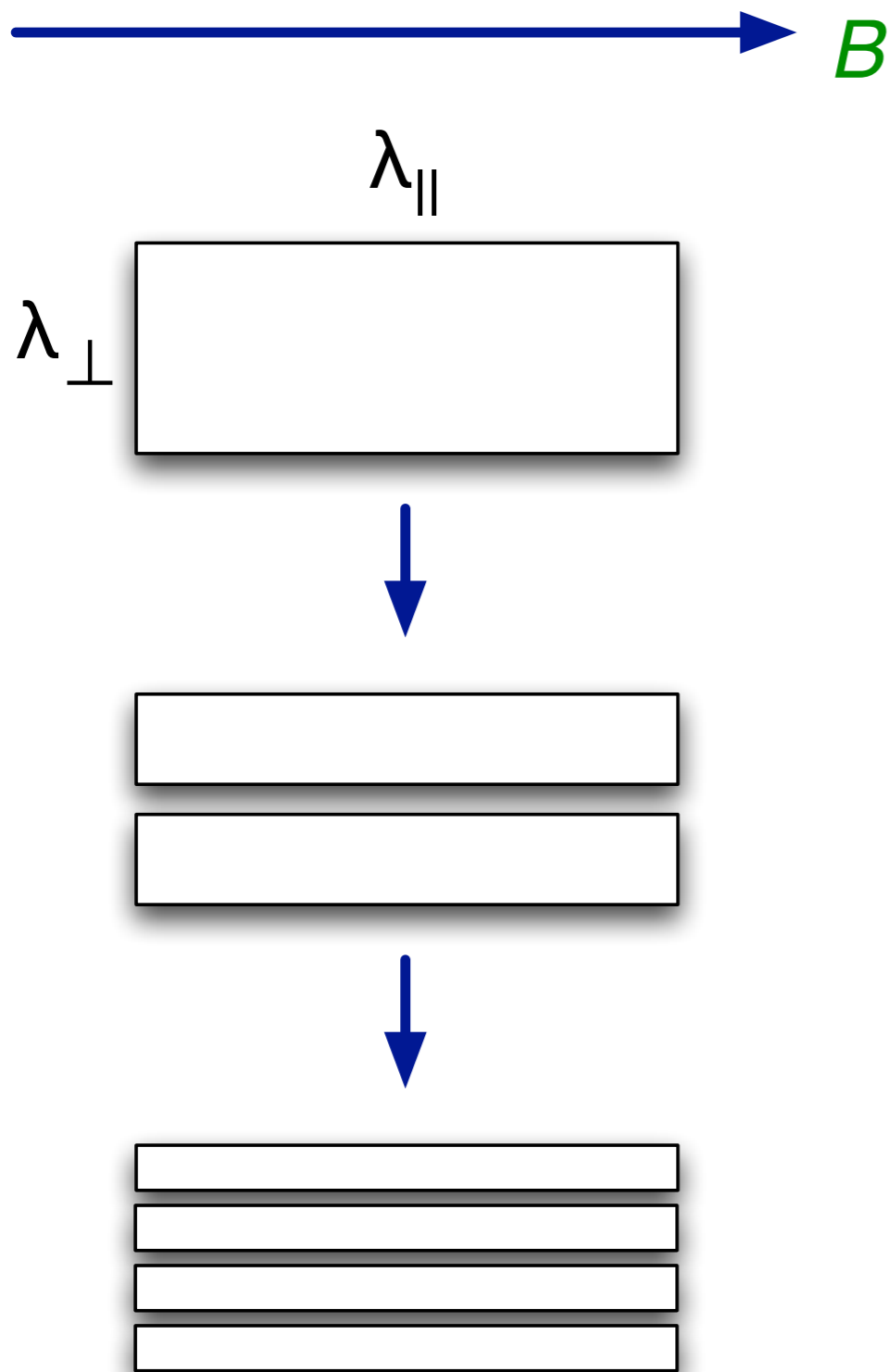

- As energy cascades to smaller scales, you can think of wave packets breaking up into smaller wave packets.
- During this process, the length  $\lambda_{||}$  of a wave packet measured parallel to  $B$  remains constant, but the length  $\lambda_{\perp}$  measured perpendicular to  $B$  gets smaller.
- Fluctuations with small  $\lambda_{\perp}$  end up being very anisotropic, with  $\lambda_{||} \gg \lambda_{\perp}$

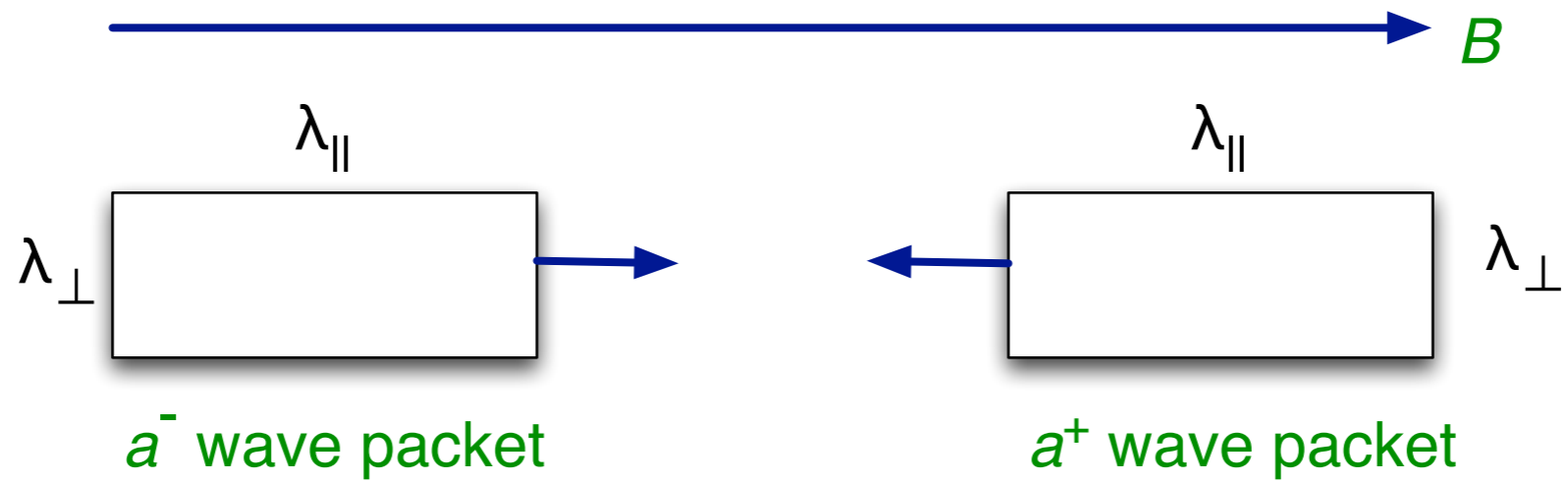

- $\delta v_{\lambda_{\perp}}$  = rms velocity difference across a distance  $\lambda_{\perp}$  in the plane perpendicular to  $\vec{B}$  = velocity fluctuation of wave packets of  $\perp$  size  $\lambda_{\perp}$ .
- The contribution of one of these wave packets to the local value of  $\vec{v} \cdot \nabla \vec{v}$  is  $\sim (\delta v_{\lambda_{\perp}})^2 / \lambda_{\perp}$ . (For AWs,  $\vec{v} \perp \vec{B}_0$ .)
- Assumption: wave packets of size  $\lambda_{\perp}$  are sheared primarily by wave packets of similar size (interactions are “local” in scale).
- A collision between two counter-propagating wave packets lasts a time  $\Delta t \sim \lambda_{\parallel} / v_A$ .
- A single collision between wave packets changes the velocity in each wave packet by an amount  $\sim \Delta t \times (\delta v_{\lambda_{\perp}})^2 / \lambda_{\perp}$
- The fractional change in the velocity in each wave packet is

$$\chi \sim \frac{\Delta t \times (\delta v_{\lambda_{\perp}})^2 / \lambda_{\perp}}{\delta v_{\lambda_{\perp}}} \sim \frac{\lambda_{\parallel} \delta v_{\lambda_{\perp}}}{v_A \lambda_{\perp}}$$

(Ng & Bhattacharjee 1997,  
Goldreich & Sridhar 1997)

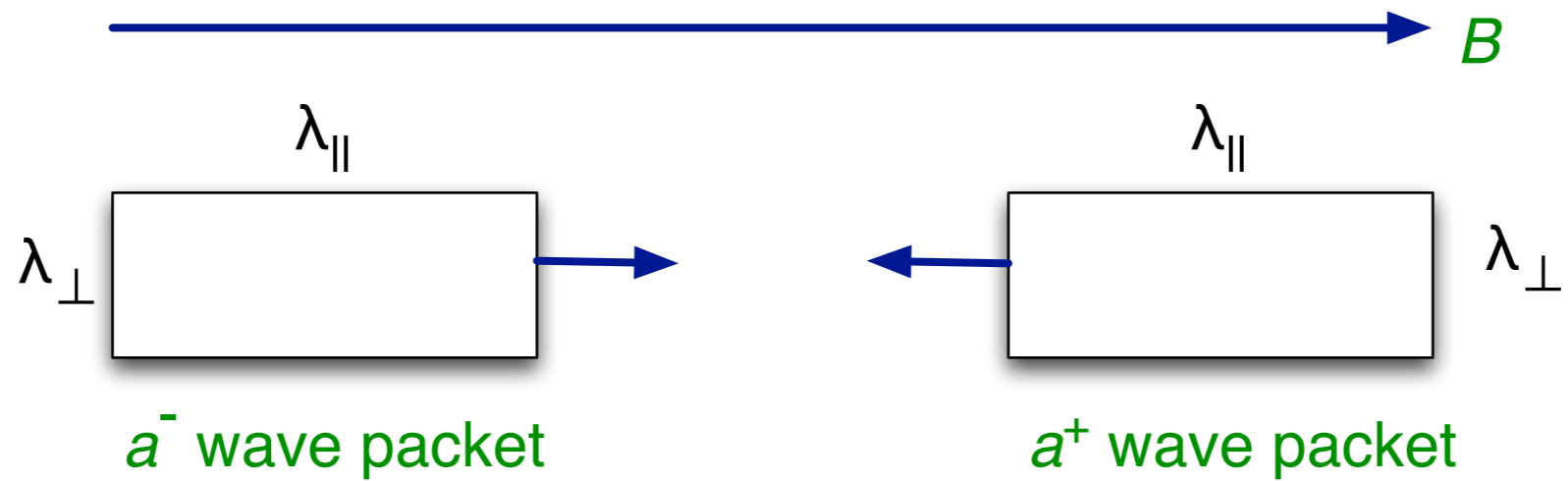

- The fractional change in the velocity in each wave packet is

$$\chi \sim \frac{\Delta t \times (\delta v_{\lambda_{\perp}})^2 / \lambda_{\perp}}{\delta v_{\lambda_{\perp}}} \sim \frac{\lambda_{\parallel} \delta v_{\lambda_{\perp}}}{v_A \lambda_{\perp}}$$

- In weak turbulence,  $\chi \ll 1$ , while in strong turbulence  $\chi \gtrsim 1$ .
- In weak turbulence, the effects of successive collisions add incoherently, like a random walk. The cumulative fractional change in a wave packet's velocity after  $N$  collisions is thus  $\sim N^{1/2} \chi$ . In order for the wave packet's energy to cascade to smaller scales, this cumulative fractional change must be  $\sim 1$ .
- This means that it takes  $N \sim \chi^{-2}$  wave packet collisions in order to cause a wave packet's energy to cascade.
- The cascade time is therefore  $\tau_c \sim N \lambda_{\parallel} / v_A \sim \chi^{-2} \lambda_{\parallel} / v_A$ .

(Ng & Bhattacharjee 1997,  
Goldreich & Sridhar 1997)

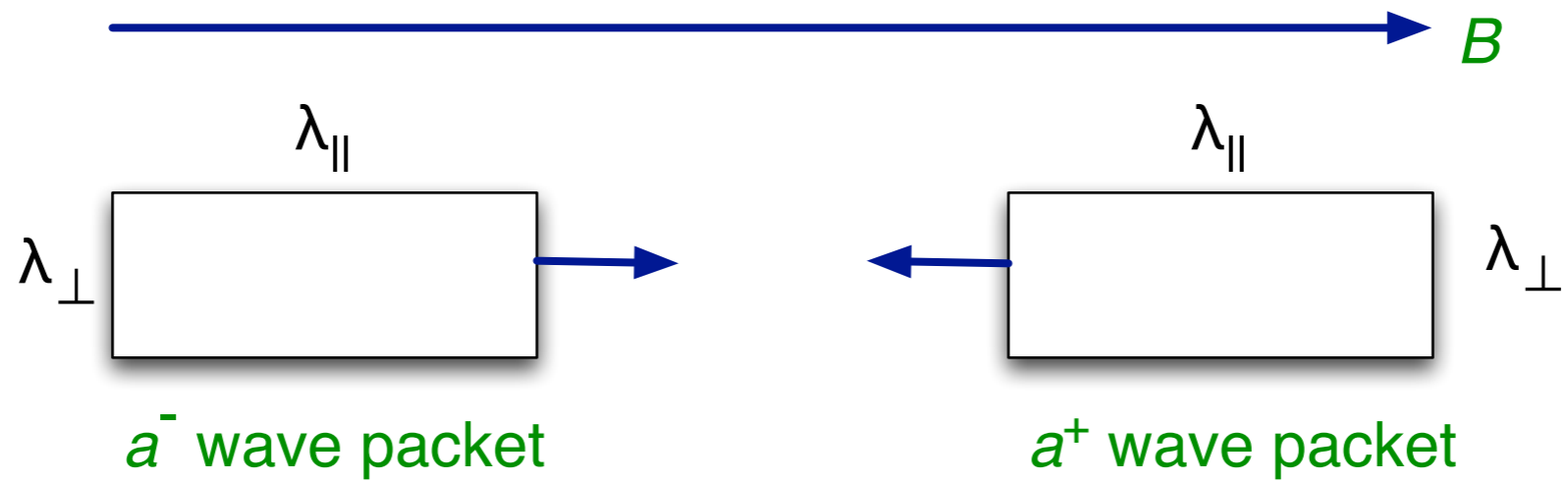

- The cascade time is therefore  $\tau_c \sim N\lambda_{\parallel}/v_A \sim \chi^{-2}\lambda_{\parallel}/v_A$ . Recalling that  $\chi = \lambda_{\parallel}\delta v_{\lambda_{\perp}}/(\lambda_{\perp}v_A)$ , we obtain

$$\tau_c \sim \frac{v_A \lambda_{\perp}^2}{\lambda_{\parallel} \delta v_{\lambda_{\perp}}^2}$$

- The cascade power  $\epsilon$  is  $\delta v_{\lambda_{\perp}}^2/\tau_c$ , or

$$\epsilon \sim \frac{\delta v_{\lambda_{\perp}}^4 \lambda_{\parallel}}{v_A \lambda_{\perp}^2}$$

- Noting that  $\epsilon$  is independent of  $\lambda_{\perp}$  within the inertial range, and that  $\lambda_{\parallel}$  is constant, we obtain  $v_{\lambda_{\perp}} \propto \lambda_{\perp}^{1/2}$ . **(Ng & Bhattacharjee 1997)**
- Substituting this scaling into the expression for  $\chi$ , we find that  $\chi \propto \lambda_{\perp}^{-1/2}$ . At sufficiently small scales,  $\chi$  will increase to  $\sim 1$ , and the turbulence will become strong!



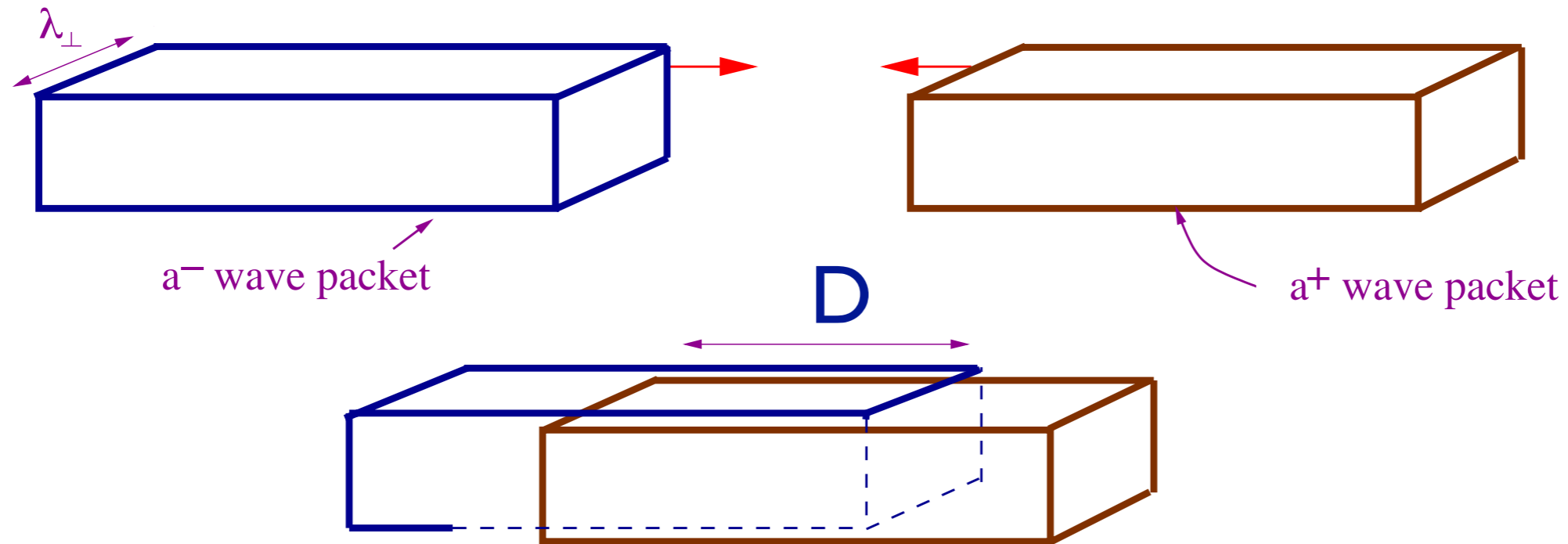

- after colliding wave packets have inter-penetrated by a distance  $D$  satisfying the relation

$$\frac{D}{v_A} \times \frac{\delta v_{\lambda_{\perp}}}{\lambda_{\perp}} \sim 1$$

the leading edge of each wave packet will have been substantially sheared/alterred relative to the trailing edge. The parallel length of the wave packet therefore satisfies  $\lambda_{\parallel} \lesssim D$ , or equivalently  $\chi \lesssim 1$ .

- In weak turbulence,  $\chi \ll 1$  but  $\chi$  grows to  $\sim 1$  as  $\lambda_{\perp}$  decreases. Once  $\chi$  reaches a value  $\sim 1$  (strong turbulence),  $\chi$  remains  $\sim 1$ , the state of “critical balance.” (Higdon 1983; Goldreich & Sridhar 1995)

# Critically Balanced, Strong AW Turbulence

(Higdon 1983; Goldreich & Sridhar 1995)

- In critical balance,

$$\chi = \frac{\lambda_{\parallel}}{v_A} \times \frac{\delta v_{\lambda_{\perp}}}{\lambda_{\perp}} \sim 1$$

and the linear time scale  $\lambda_{\parallel}/v_A$  is comparable to the nonlinear time scale  $\lambda_{\perp}/\delta v_{\lambda_{\perp}}$  at each perpendicular scale  $\lambda_{\perp}$ , and the turbulence is said to be “strong.”

- the energy cascade obeys the same arguments as hydrodynamic turbulence:  $\tau_c \sim \lambda_{\perp}/\delta v_{\lambda_{\perp}}$  and  $\epsilon \sim \delta v_{\lambda_{\perp}}^2/\tau_c \sim \delta v_{\lambda_{\perp}}^3/\lambda_{\perp}$ .
- Since the cascade power  $\epsilon$  is independent of  $\lambda_{\perp}$  in the inertial range,  $\delta v_{\lambda_{\perp}} \propto \lambda_{\perp}^{1/3}$ .
- the condition  $\chi \sim (\lambda_{\parallel}/v_A) \times (\delta v_{\lambda_{\perp}}/\lambda_{\perp}) \sim 1$  then implies that  $\lambda_{\parallel} \propto \lambda_{\perp}^{2/3}$ .

# Some Open Questions

- What is the origin of Alfvén waves propagating towards the Sun in the solar-wind rest frame? (Reflection? Velocity-shear instabilities?)
- At small scales, where MHD no longer applies, what is the proper description of solar-wind turbulence?
- Which microphysical processes are responsible for the dissipation of solar wind turbulence at small scales? (Cyclotron heating? Landau damping? Stochastic heating? Magnetic reconnection?)
- What are the processes at the Sun that launch waves into the solar wind? Which types of waves are launched, and what are the power spectra of these waves at the base of the solar atmosphere?

# Summary

- Turbulence is measured at all locations that spacecraft have explored in the solar wind.
- Alfven-wave turbulence likely accounts for most of the energy in solar-wind turbulence.
- Alfven waves may provide the energy required to power the solar wind, and Alfven-wave turbulence may be the mechanism that allows the wave energy to dissipate and heat the solar-wind plasma.
- Solar Probe Plus will provide the in situ measurements needed to determine the mechanisms that heat and accelerate the solar wind within the solar-wind acceleration region.

## References

- Belcher, J. W., & Davis, Jr., L. 1971, *Journal of Geophysical Research*, 76, 3534
- Bruno, R., & Carbone, V. 2005, *Living Reviews in Solar Physics*, 2, 4
- Chandran, B. D. G., & Hollweg, J. V. 2009, *Astrophysical Journal*, 707, 1659
- Chandran, B. D. G., Li, B., Rogers, B. N., Quataert, E., & Germaschewski, K. 2010, *Astrophysical Journal*, 720, 503
- Chaston, C. C., Bonnell, J. W., Carlson, C. W., McFadden, J. P., Ergun, R. E., Strangeway, R. J., & Lund, E. J. 2004, *Journal of Geophysical Research (Space Physics)*, 109, 4205
- Chen, L., Lin, Z., & White, R. 2001, *Physics of Plasmas*, 8, 4713
- Cranmer, S. R., Matthaeus, W. H., Breech, B. A., & Kasper, J. C. 2009, *Astrophysical Journal*, 702, 1604
- Cranmer, S. R., & van Ballegooijen, A. A. 2005, 156, 265
- De Pontieu, B., et al. 2007, *Science*, 318, 1574
- Dmitruk, P., Matthaeus, W. H., Milano, L. J., Oughton, S., Zank, G. P., & Mullan, D. J. 2002, *Astrophysical Journal*, 575, 571
- Dobrowolny, M., Mangeney, A., & Veltri, P. 1980, *Physical Review Letters*, 45, 144
- Frisch, U., Pouquet, A., Leorat, J., & Mazure, A. 1975, *Journal of Fluid Mechanics*, 68, 769
- Galtier, S., Nazarenko, S. V., Newell, A. C., & Pouquet, A. 2000, *Journal of Plasma Physics*, 63, 447
- Goldreich, P., & Sridhar, S. 1995, *Astrophysical Journal*, 438, 763
- Howes, G. G., Cowley, S. C., Dorland, W., Hammett, G. W., Quataert, E., & Schekochihin, A. A. 2008a, *Journal of Geophysical Research (Space Physics)*, 113, 5103
- Iroshnikov, P. S. 1963, *Astronomicheskii Zhurnal*, 40, 742
- Kennel, C., & Engelmann, F. 1966, *Phys. Fluids*, 9, 2377
- Kolmogorov, A. N. 1941, *Dokl. Akad. Nauk SSSR*, 30, 299
- Kraichnan, R. H. 1965, *Physics of Fluids*, 8, 1385
- Maron, J., & Goldreich, P. 2001, *Astrophysical Journal*, 554, 1175
- Matthaeus, W. H., Zank, G. P., Leamon, R. J., Smith, C. W., Mullan, D. J., & Oughton, S. 1999, *Space Science Reviews*, 87, 269
- McChesney, J. M., Stern, R. A., & Bellan, P. M. 1987, *Physical Review Letters*, 59, 1436
- Ng, C. S., & Bhattacharjee, A. 1996, *Astrophysical Journal*, 465, 845
- . 1997, *Physics of Plasmas*, 4, 605
- Podesta, J. J., Roberts, D. A., & Goldstein, M. L. 2007, *Astrophysical Journal*, 664, 543
- Schekochihin, A. A., Cowley, S. C., Dorland, W., Hammett, G. W., Howes, G. G., Quataert, E., & Tatsuno, T. 2009, *Astrophysical Journal Supplement*, 182, 310
- Shebalin, J. V., Matthaeus, W., & Montgomery, D. 1983, *Journal of Plasma Physics*, 29, 525

Stix, T. H. 1992, *Waves in Plasmas* (New York: Springer-Verlag)

Tomczyk, S., McIntosh, S. W., Keil, S. L., Judge, P. G., Schad, T., Seeley, D. H., & Edmondson, J. 2007, *Science*, 317, 1192

Vasquez, B. J., Smith, C. W., Hamilton, K., MacBride, B. T., & Leamon, R. J. 2007, *Journal of Geophysical Research (Space Physics)*, 112, 7101

Velli, M., Grappin, R., & Mangeney, A. 1989, *Physical Review Letters*, 63, 1807

Verdini, A., Grappin, R., Pinto, R., & Velli, M. 2012, *Astrophysical Journal Letters*, 750, L33