

# Heliophysical Particle Radiation: Universal Processes and Problems

**J.C. Green**

*Space Weather Prediction Center  
July 28, 2008*

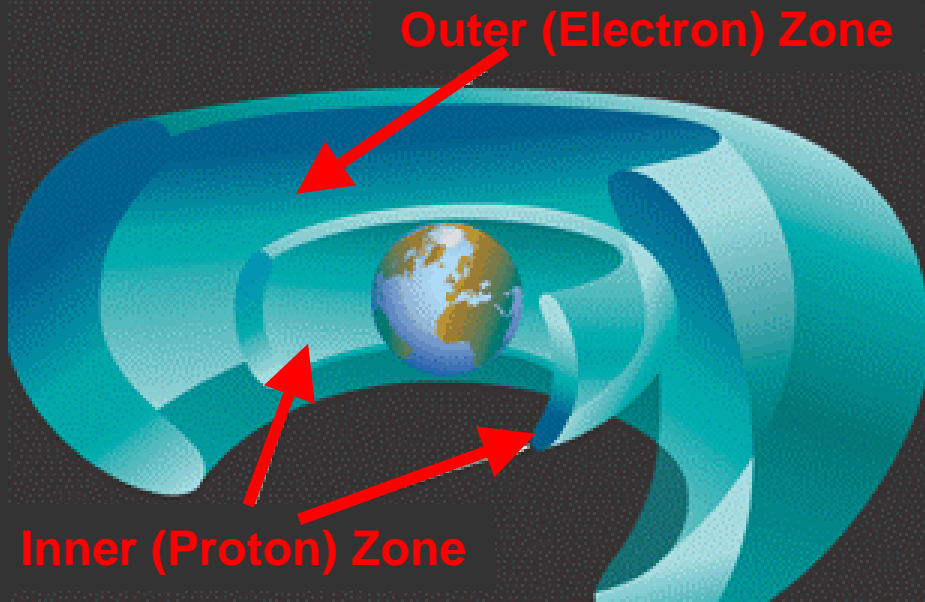

# Outline

- Introduction to planetary radiation
- Single/Collective Particle Motion
- Acceleration Mechanisms
- Loss Mechanisms
- Models

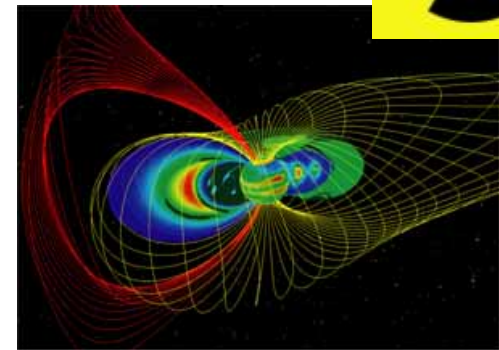

# Intro to Radiation Belts

- Earth's radiation belts were discovered in 1958 by Dr. Van Allen's experiment on Explorer I.
- Explorer I was the first American satellite to orbit Earth and the first to suffer a space weather related issue.

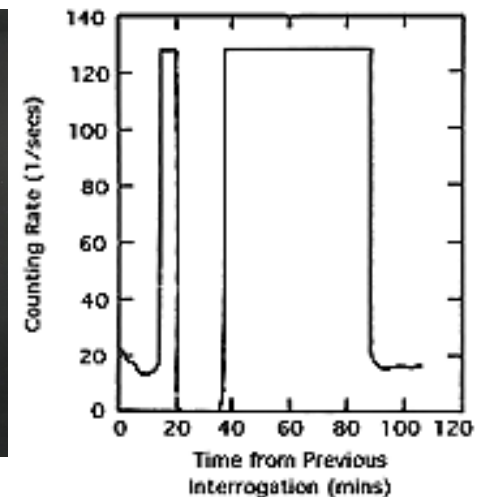
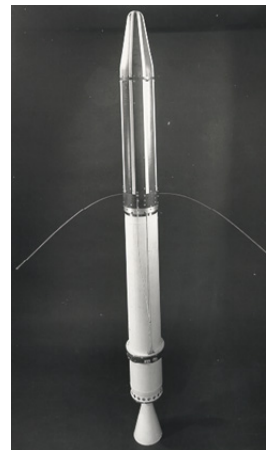

# Introduction to Earth's Electron Radiation Belts

## Basic Facts

- Particle energies  $>.1$  MeV
- Inner belt 1.5-3 Re  
Outer belt 3-10 Re.
- Slot region: flux minimum at  $\sim 3$  Re formed by enhanced loss due to interaction with whistler waves.
- Structure and dynamics of proton and electron belts differs so they are studied separately.
- Radiation belt electrons = relativistic electrons

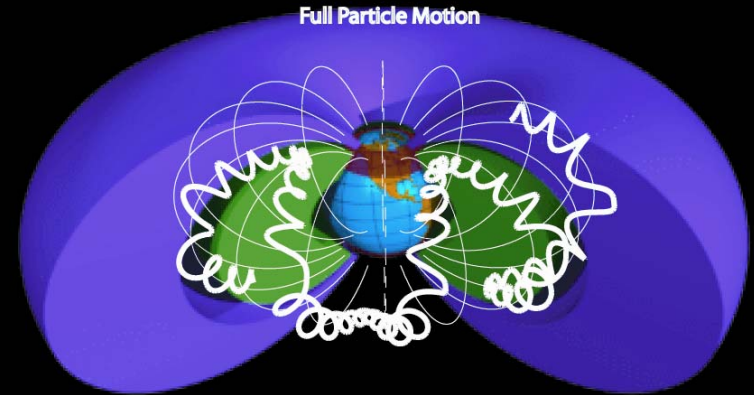

# Introduction to Earth's electron Radiation Belts

## Sampex 2-6 MeV electron flux

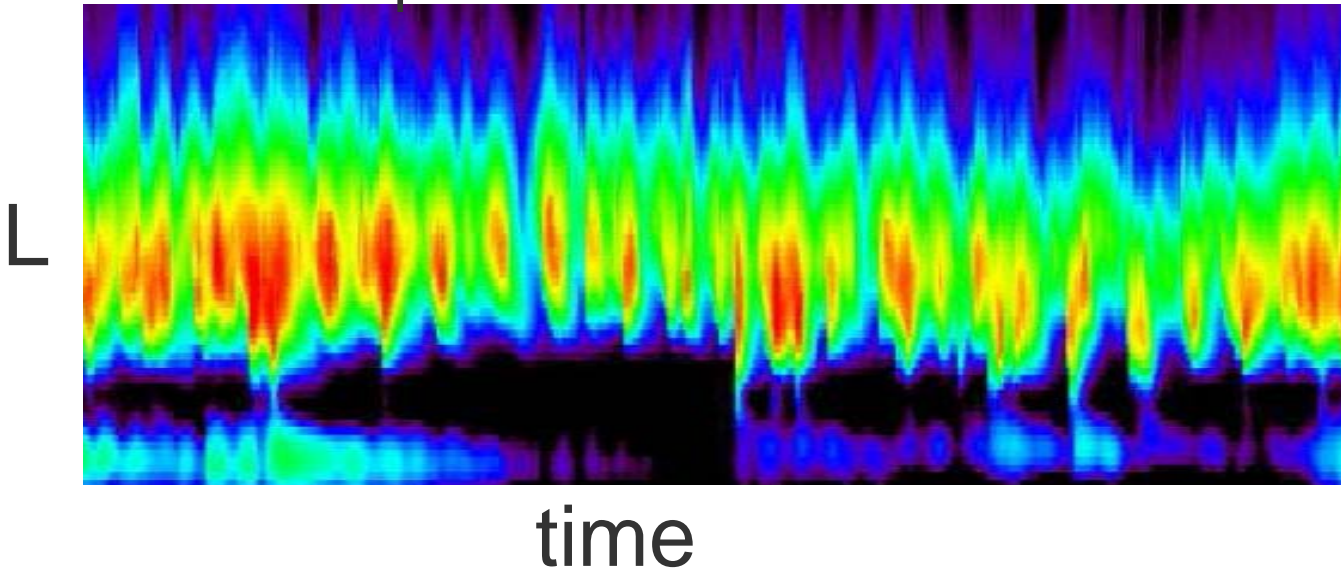

- Electron radiation belts are highly variable

The L parameter is a magnetic coordinate that organizes particle motion. In a dipole field the L value is the radial distance from Earth where a field line crosses the equator.

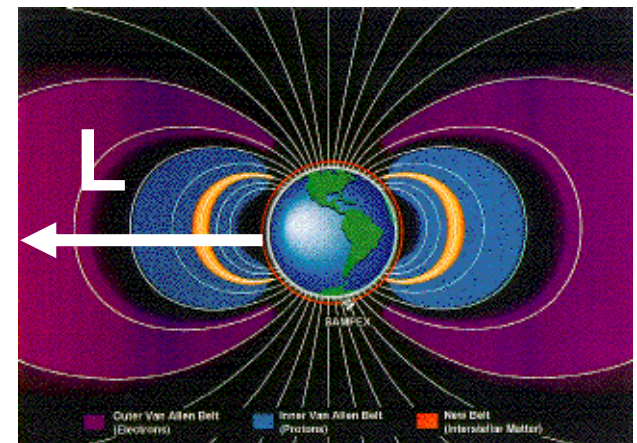

# Introduction to Earth's Proton Radiation Belts

Salamambo code simulation

- Energies  $>10$  MeV
- $L \sim 1-5$
- Just one belt as opposed to two.

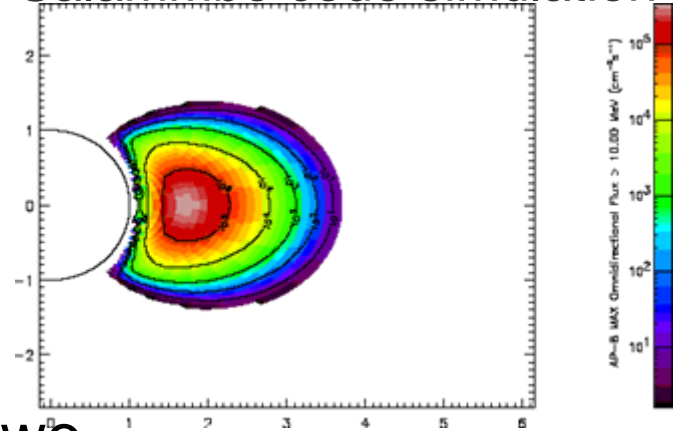

CRESS Measurements

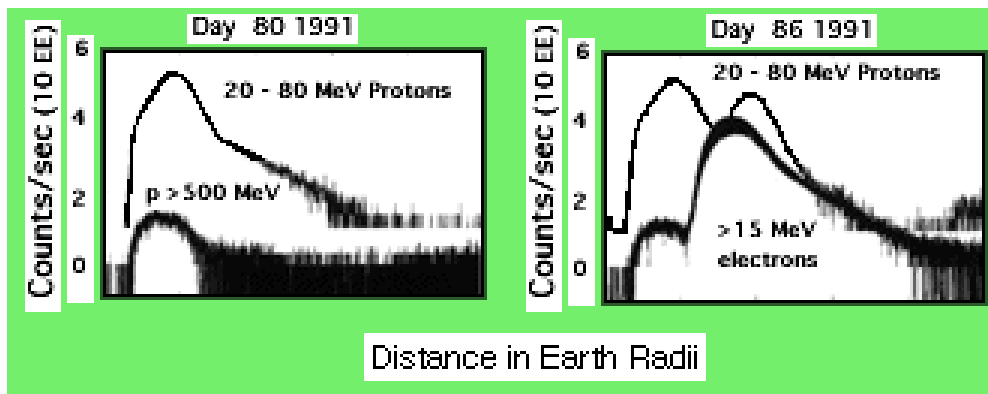

- Less variable on average but changes are dramatic.

# Planetary radiation

- Jupiter

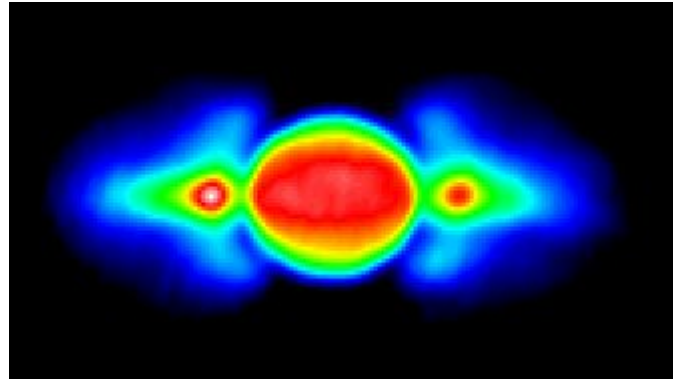

- Saturn

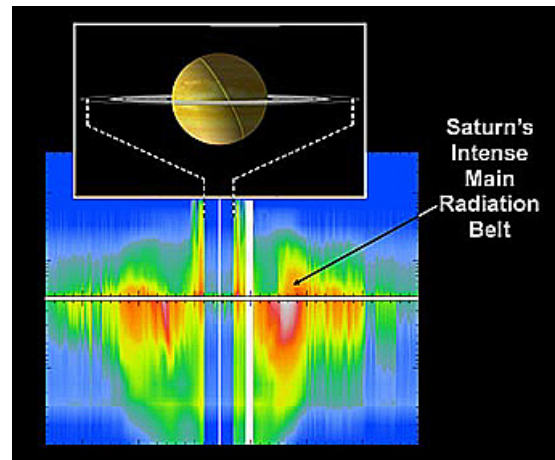

# Single/Collective Particle Motion

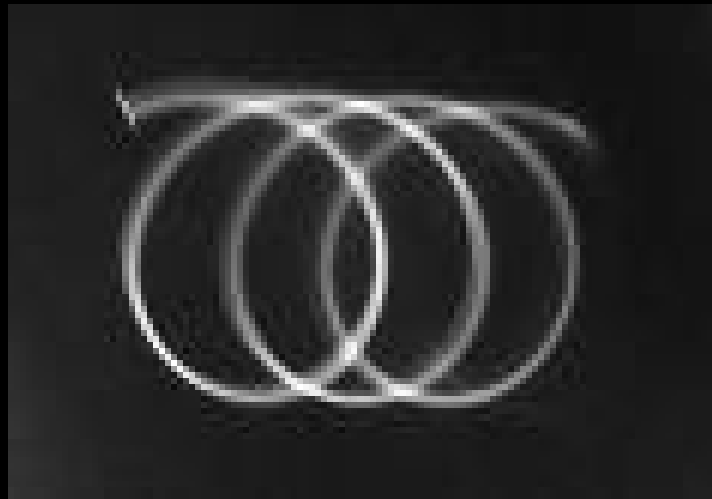



# Particle Motion

Gyro-motion around field lines:

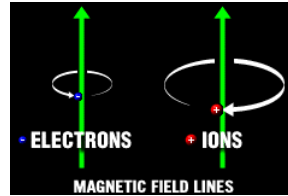

+

Bounce motion along field lines:

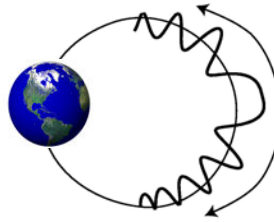

+

Drift motion around the earth:

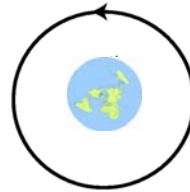

+

= All motion

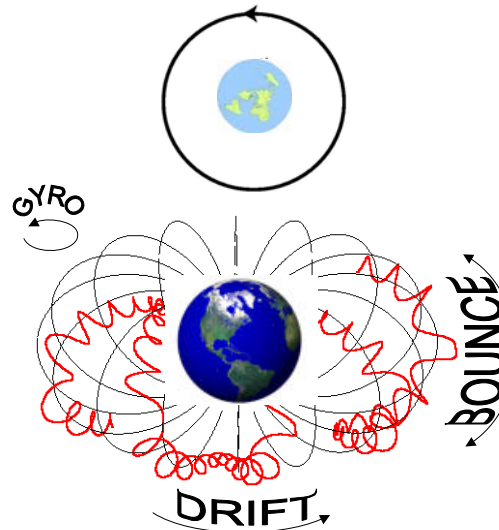

# Bounce Motion

- Lorentz Force:  $F=q(E+v \times B)$

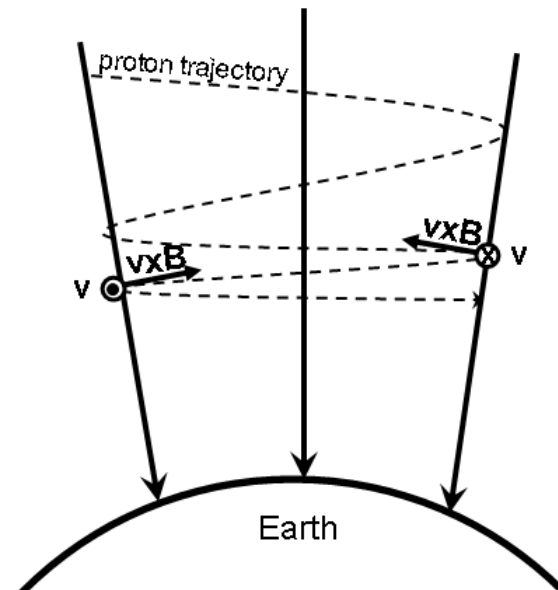
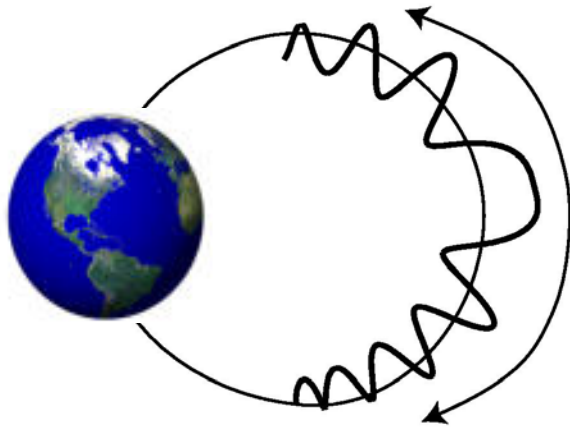

# Drift Motion

- Caused by the radial gradient of the planet's magnetic field.
- Protons drift westward and electrons drift eastward.
- Intuitively explained by the changing gyroradius in the different magnetic field strengths.
- The gradient drift is proportional to energy. Radiation belt electrons orbit Earth in less than 10 minutes.

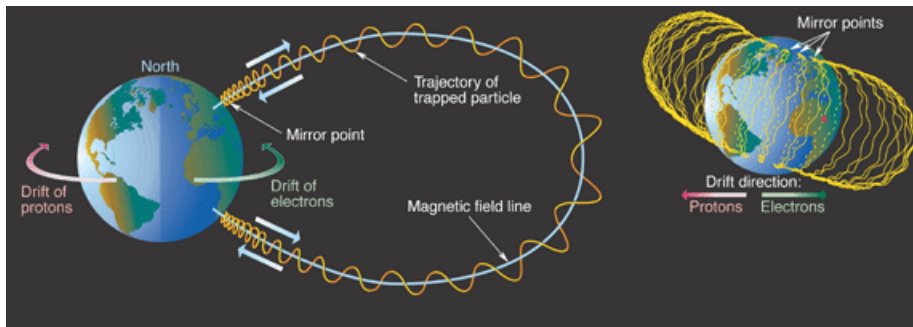
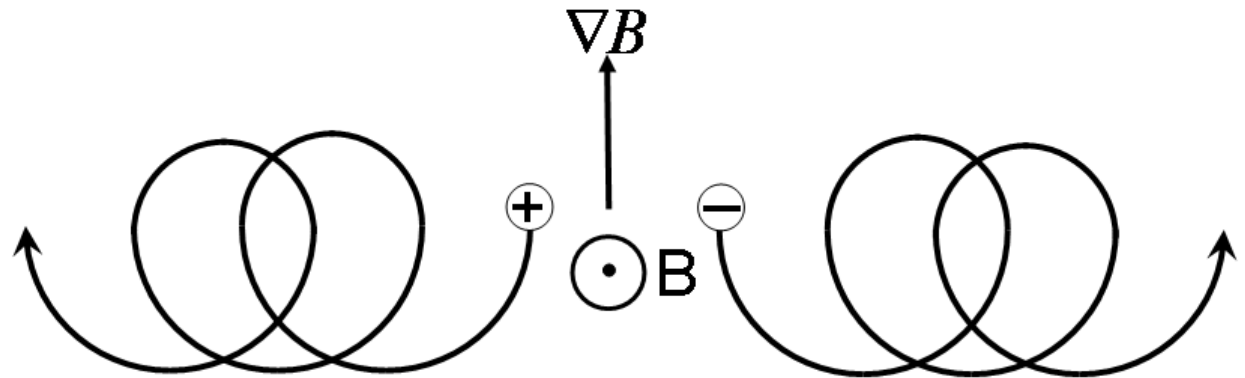

# Invariants

- There are 3 invariants associated with the 3 types of oscillatory motion. These invariants are conserved when the magnetic field changes slowly compared to the timescale of the motion.

- First Invariant:  $\mu = \frac{p_{\perp}^2}{2 m_0 B}$

- Second Invariant:  $J = \oint p_{\parallel} ds$

$$K = \frac{J}{2\sqrt{2m_0\mu}} = I\sqrt{B_m} = \int_{s_m}^{s_m'} [B_m - B(s)]^{\frac{1}{2}} ds$$

- Third invariant

$$\Phi = \int (\nabla \times A) dS = \int B dS$$

$$L^* = \frac{2\pi M}{\Phi R_E}$$

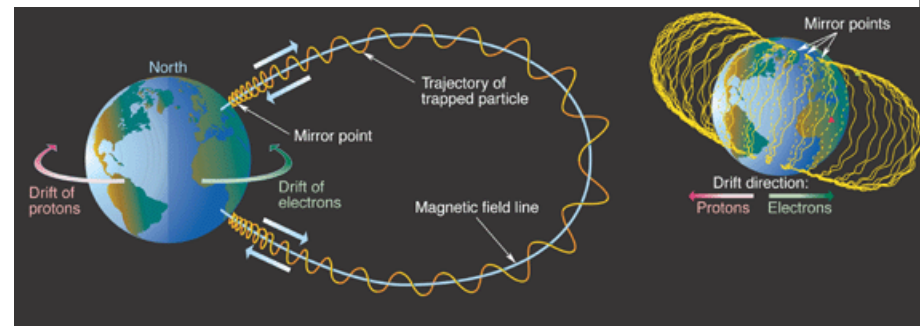

# Phase Space Density

- Phase space density is the number of particles per volume and per momentum.

$$N = \iint f(\vec{x}, \vec{p}) dx dp$$

- Phase space density  $f=j/p^2$
- Liouville's theorem states that the phase space density remains constant along a trajectory in phase space.
- $f(\mu, K, L^*)$  will not change unless one of the invariants is broken.

# Acceleration Mechanisms

- 1.0 Earth's electron radiation belts
- 2.0 Earth's proton radiation belts
- 3.0 Jupiter and Saturn

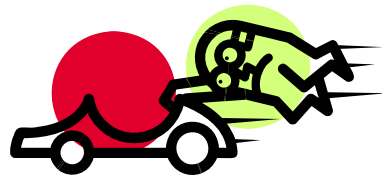

# Acceleration of electrons: Earth's radiation belts

External Source vs. Internal Source

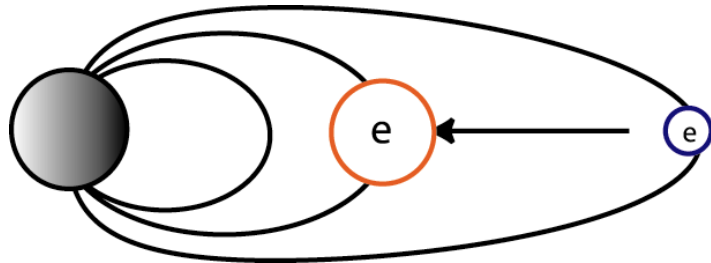

- Shock acceleration
- Substorm acceleration
- ULF wave enhanced radial diffusion**

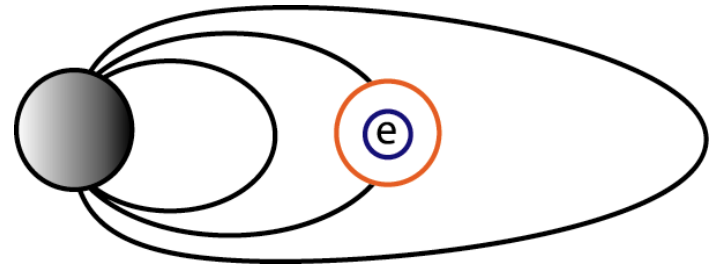

- Whistler chorus wave acceleration**
- Nonlinear whistler chorus wave acceleration

# External Source Acceleration Mechanisms

- Can be understood by the assumption that  $\mu$  is conserved.
- External mechanisms rely on some form of an electric field to transport electrons Earthward where the magnetic field is stronger.
- If  $\mu$  is conserved, then the perpendicular energy must also increase.



# External Source: Shock acceleration

- The shock acceleration mechanism suggests that electrons are accelerated by an induced electric field created as shocked solar wind passes the magnetosphere.
- However, a parametric study by Gannon et al. suggests that this mechanism cannot explain the common variations of the belts.

Energetic Electron, Electric and Magnetic Fields  
24 March 1991

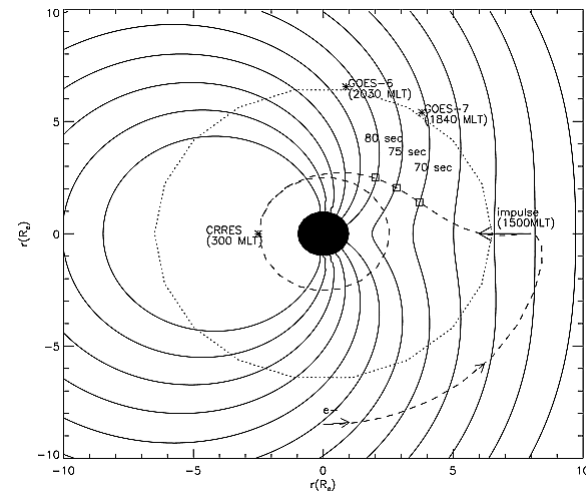
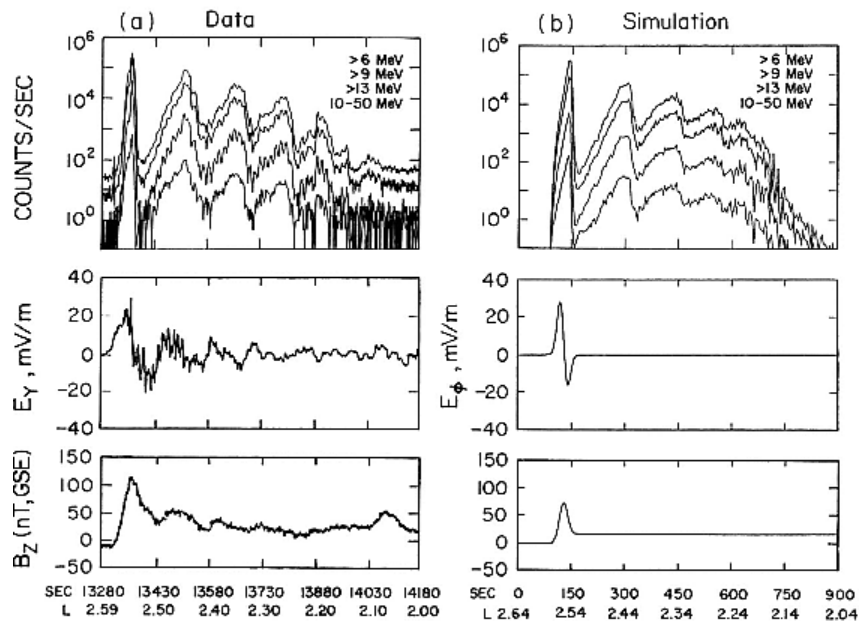

## External Source: Substorm acceleration

- The substorm acceleration mechanism suggests that electrons are accelerated by a large scale induced electric field produced when the magnetotail is reconfigured during a substorm.
- Lower energy electrons have successfully been modeled.
- At least one study suggests that high energy electron measurements are consistent with substorm acceleration.
- However, Kim et al. showed that substorms cannot move MeV electrons inside of  $L=10$ . They may produce important 'seed' electrons.

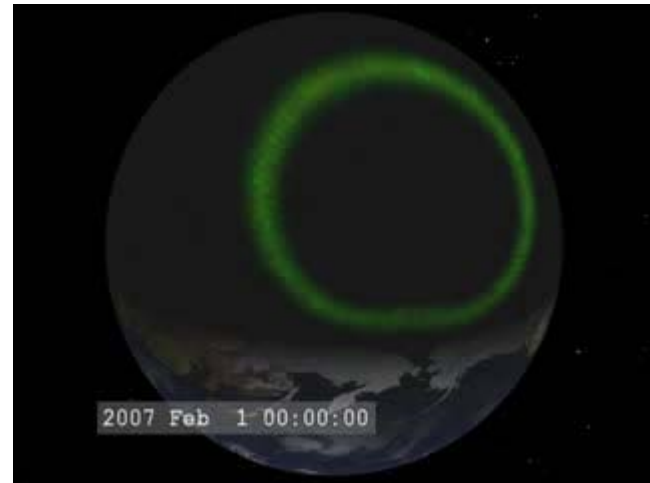

# Radial Diffusion

- Small random perturbations of the electrons radial motion causes electrons to move radially inward like diffusion in a gas.
- If  $\mu$  is conserved and the electron has moved inward to a higher B then its perpendicular energy must increase.
- The process can be described by a Fokker Plank equation.

$$\frac{\partial f(L, \mu, K, t)}{\partial t} = -\frac{\partial}{\partial L} D_1(L) f(L, \mu, K, t) + \frac{\partial^2}{\partial L^2} D_2(L) f(L, \mu, K, t) \quad D_1 = \langle L - L_0 \rangle / \tau \quad D_2 = \langle (L - L_0)^2 \rangle / \tau$$

# Radial Diffusion

- The tricky part is determining what is causing the radial perturbations and deriving the diffusion coefficients.
- At first the mechanism was not considered viable because the methods for deriving the diffusion coefficients gave timescales that were much too long to explain the observations.

$$D_1 = \langle L - L_0 \rangle / \tau$$

$$D_2 = \langle (L - L_0)^2 \rangle / \tau$$

# Radial Diffusion

- Falthammer 1965 recognized that diffusion could be caused by a resonance between electrons drifting at the same frequency as a ULF wave.

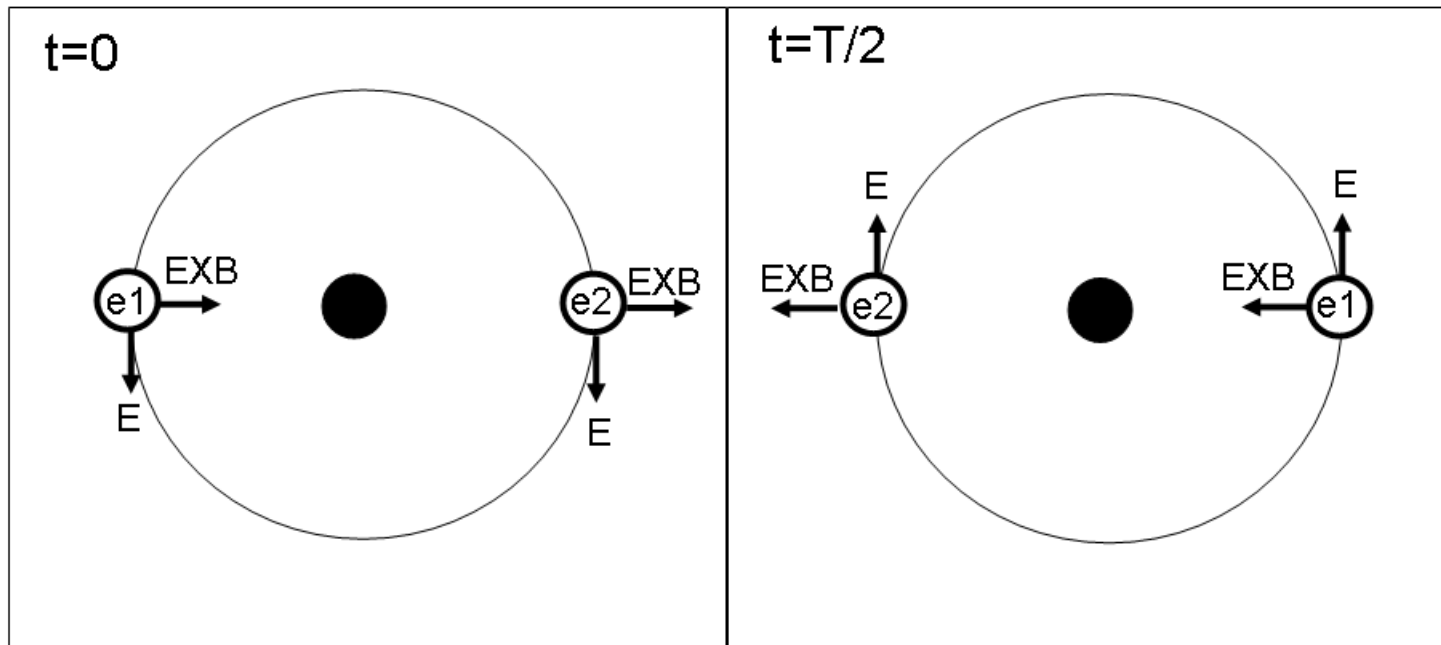

# Radial Diffusion

- If the phase of the waves is random or if there is a spectrum of wave frequencies, a few particles will see the exact electric field to move inward or outward.
- Net acceleration occurs when there is higher phase space density at larger  $L$ .

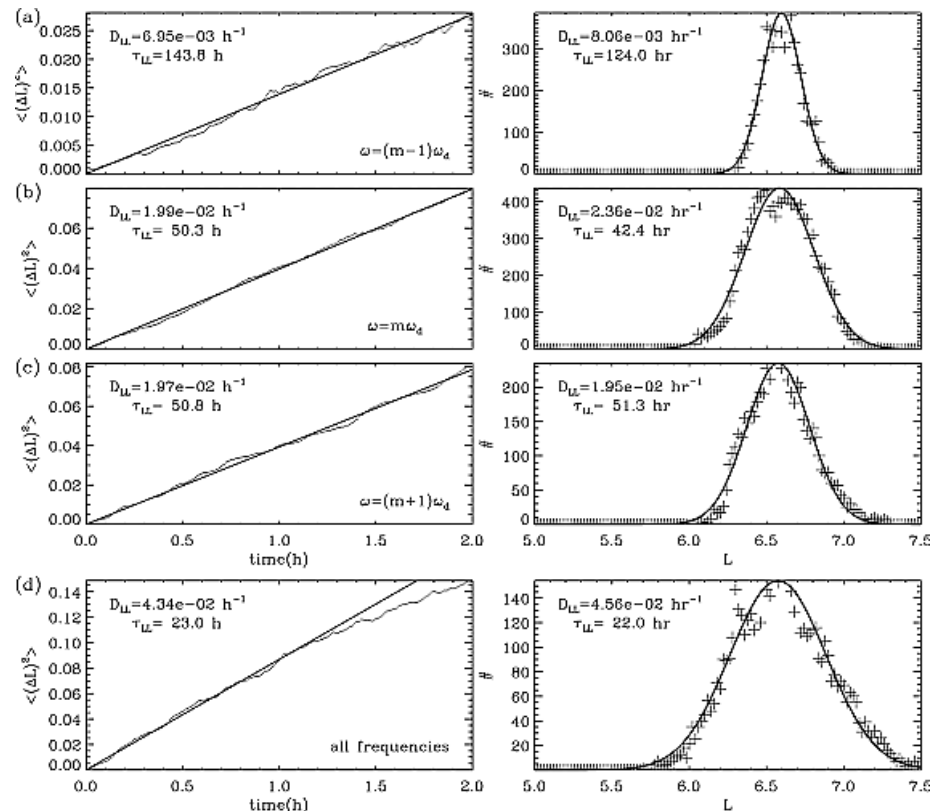

# Radial Diffusion

- Became the accepted explanation for electron radiation belt acceleration at Earth.
- But... new observations showed faster acceleration than expected causing researchers to consider alternative acceleration mechanisms.
- Radial diffusion was revisited to include effects of non-dipolar magnetic fields and faster timescales were derived.

# Internal Acceleration: Whistler chorus wave acceleration

- The basic premise is similar to radial diffusion.
- In this case, the resonance is related to the gyro-motion.
- The electron moves parallel to the field and gyrates about the field in such a way that it sees a constant electric field from the wave.

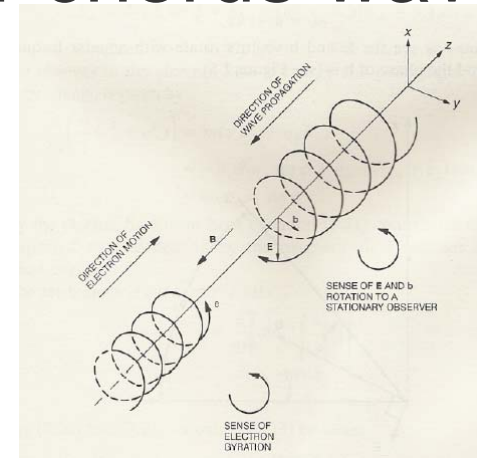

$$\omega - k \cos \theta v_{\parallel} = \frac{\Omega_g}{\gamma}$$



# Internal Acceleration: Whistler chorus wave acceleration

- If the wave amplitudes are small, the problem can be treated as a diffusive process.
- In this case, the electrons are diffusing in energy as well as pitch angle.
- The energy and pitch angle will change together.
- The curve defining the motion is called the diffusion curve and can be found by assuming the energy does not change in the wave reference frame.

# Internal Acceleration: Whistler chorus wave acceleration

- Genderin 1968 gives an intuitive manner for defining net energy gain and pitch angle changes.

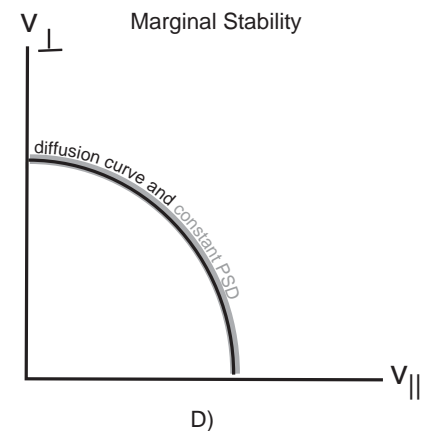
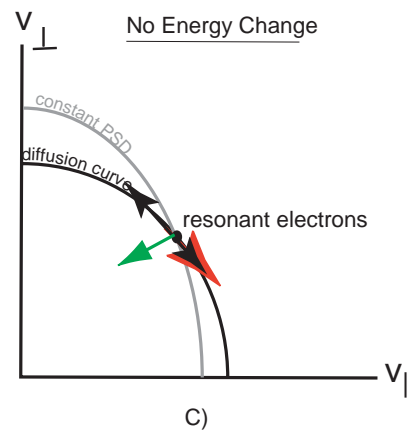
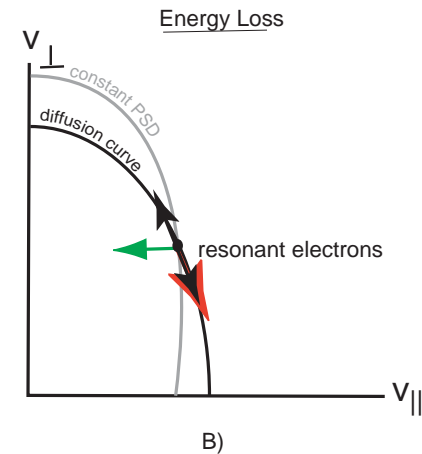
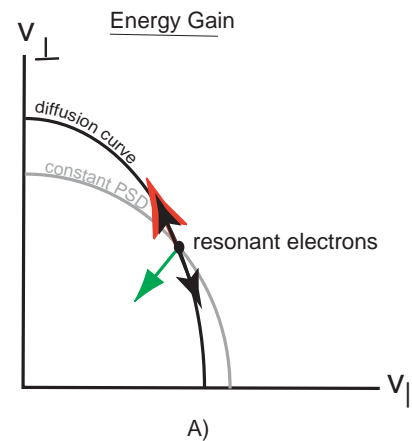

# Internal Acceleration: Whistler chorus wave acceleration

- The chorus acceleration mechanism suggests that electrons are accelerated by the interaction with chorus and EMIC waves.
- The chorus waves cause electrons to diffuse to higher energy and larger pitch angles.
- The EMIC waves isotropize the pitch angle distribution but do not change the energy.
- The isotropic distribution allows electrons to move to higher energy and larger pitch angle once again when they encounter chorus.

SUMMERS ET AL.: WAVE-PARTICLE RESONANT DIFFUSION

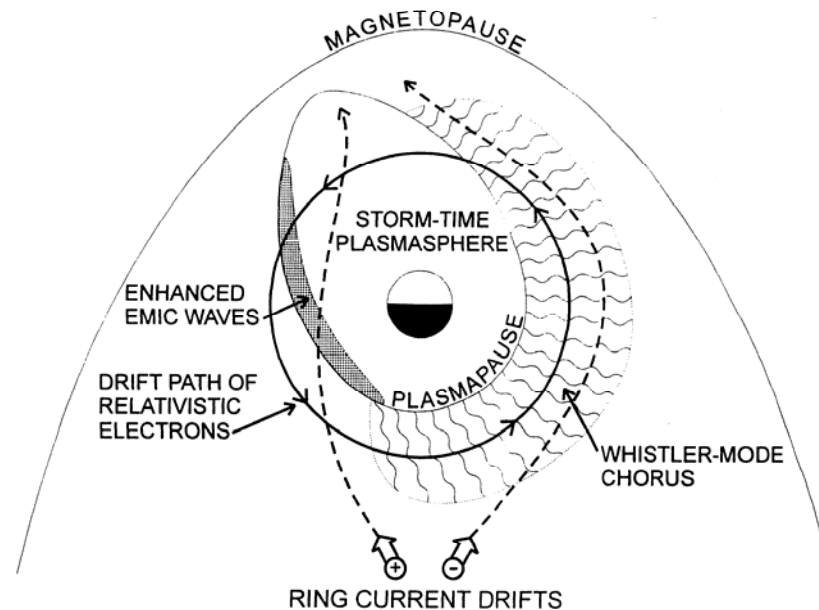

# Internal Acceleration: Non-linear Whistler chorus wave acceleration

- Diffusion assumes that electrons interact with uncorrelated wave packets that give the electrons random kicks in energy and pitch angle.
- If the wave amplitudes are large, diffusion is not a valid approximation.
- Previous statistical studies gave chorus wave amplitudes of .2 mV/m.
- Recent observations from STEREO suggest that wave amplitudes are very very large (~100 mV/m)
- Non-linear calculations show phase trapping.

## Really Big Whistler Waves (RBWW)

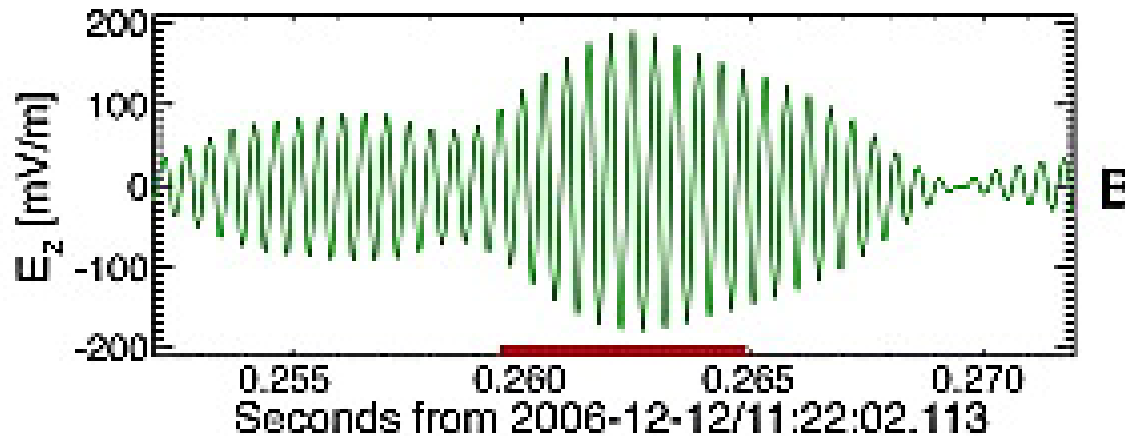

# Internal Acceleration: Non-linear Whistler chorus wave acceleration

- Relativistic turning acceleration assumes that whistler chorus is generated at the equator and propagates away from the equator.
- A small number of electrons with just the right gyrophase interact with the whistler wave as the electrons bounce towards the equator.
- The electrons are trapped with the wave and actually turn around at the equator.
- Acceleration from 100 keV to MeV in seconds.
- Ultra-relativistic acceleration predicts that an electron repeatedly undergoes the turning acceleration.

(a) Chorus wave packet ( $\omega = 0.1 \sim 0.45 \Omega_{EQ}$ )

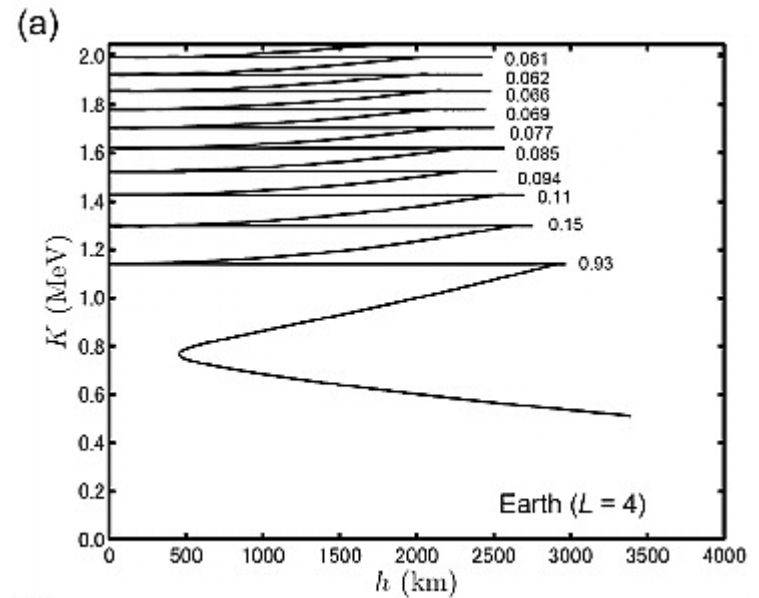
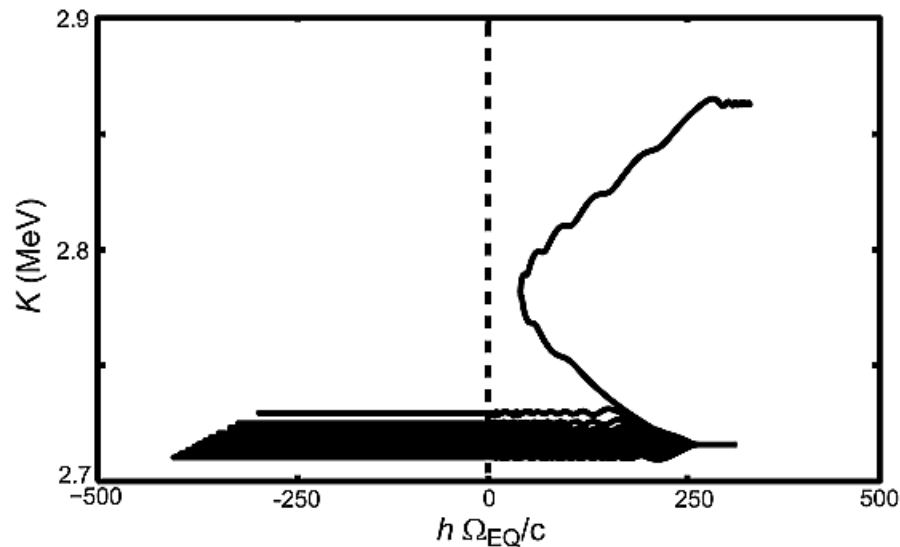

(b)

# Differentiating between internal and external acceleration using predicted phase space density (PSD) gradients

External

vs.

Internal

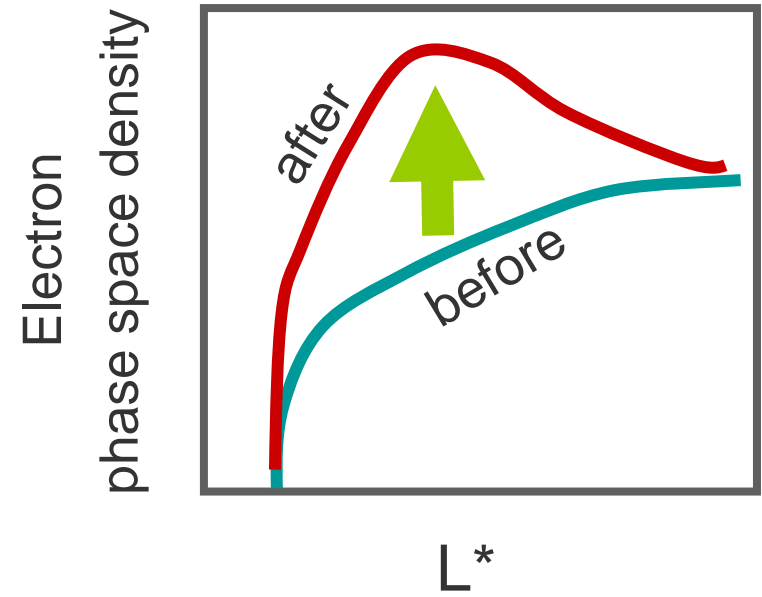
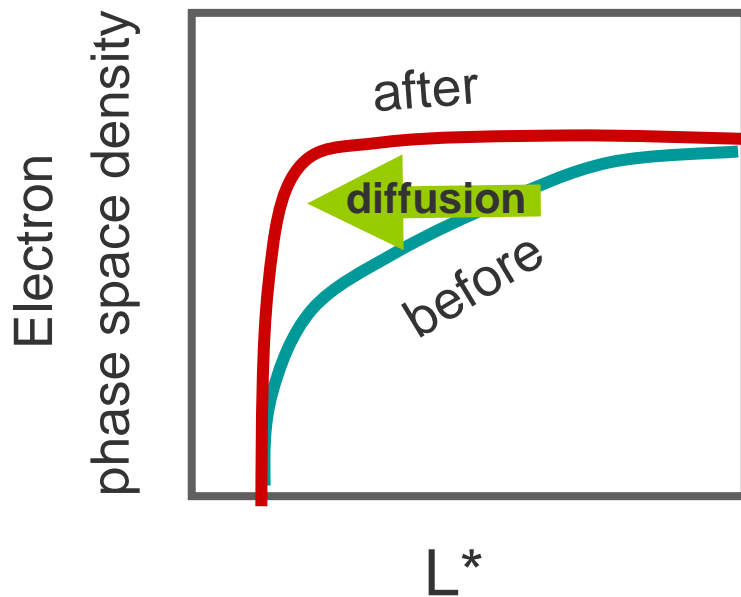

# Complications

## Losses

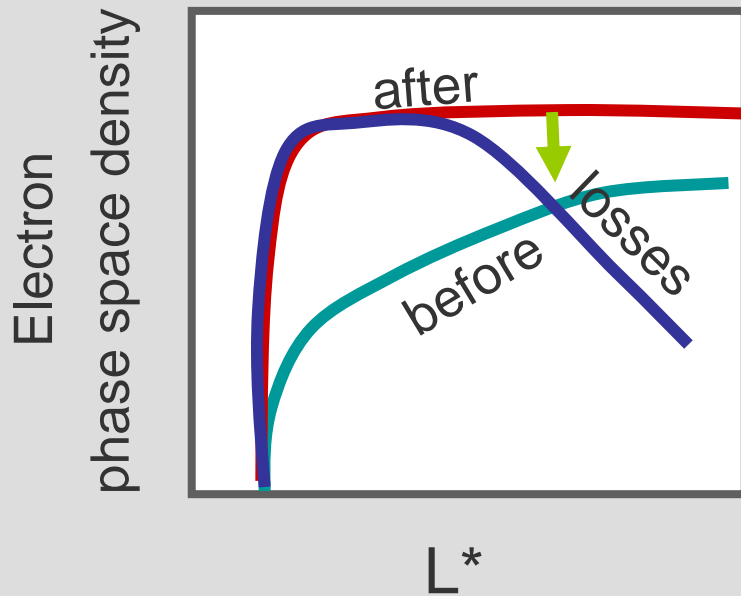

## Scattering

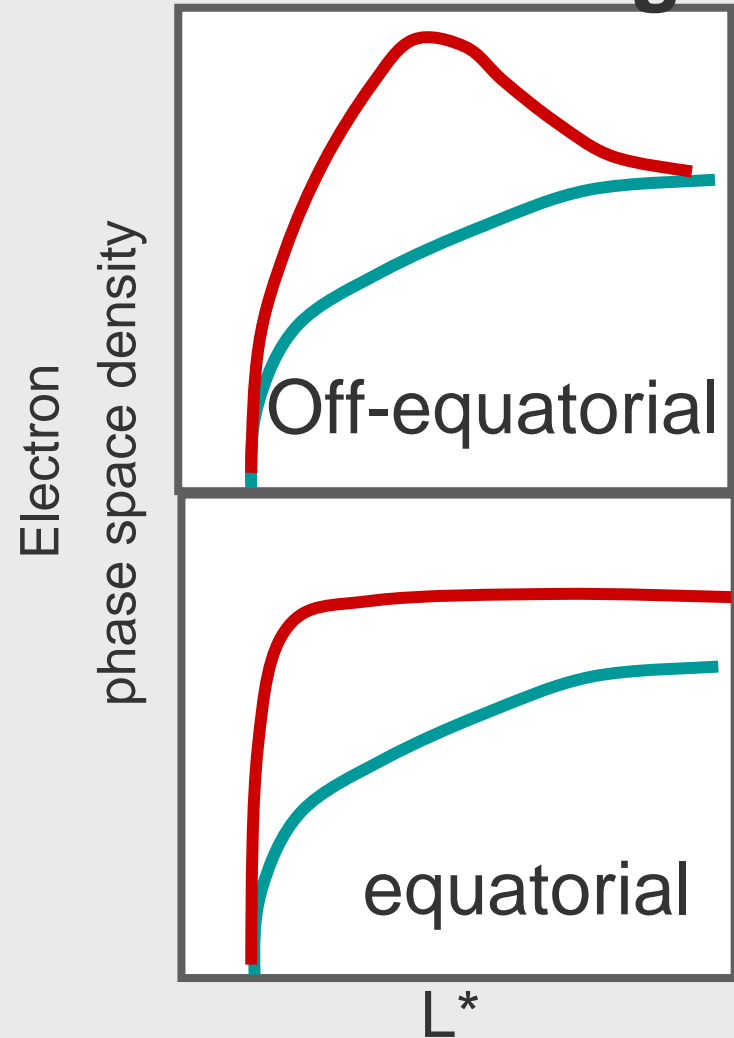

# Results

- Peaks are observed in PSD indicative of internal acceleration.
- Current thought: Both radial diffusion and whistler wave acceleration need to be included to model electron radiation belts

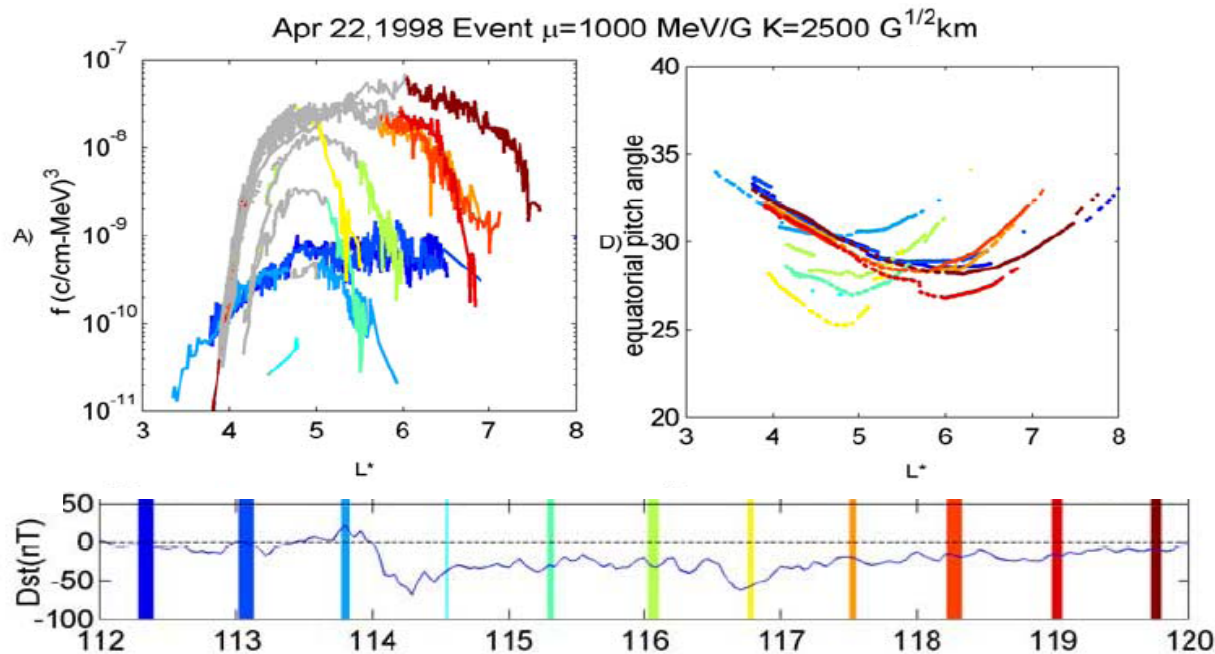



# Proton Radiation Belt Acceleration

- New proton belts are thought to be formed by large inductive electric fields caused by the compression of Earth's magnetic field as shocked solar wind passes.
- Often accompanying the shocked solar wind is a burst of very high energy protons streaming from the sun.
- The combination of the high energy proton source and induced electric field creates the new belt.

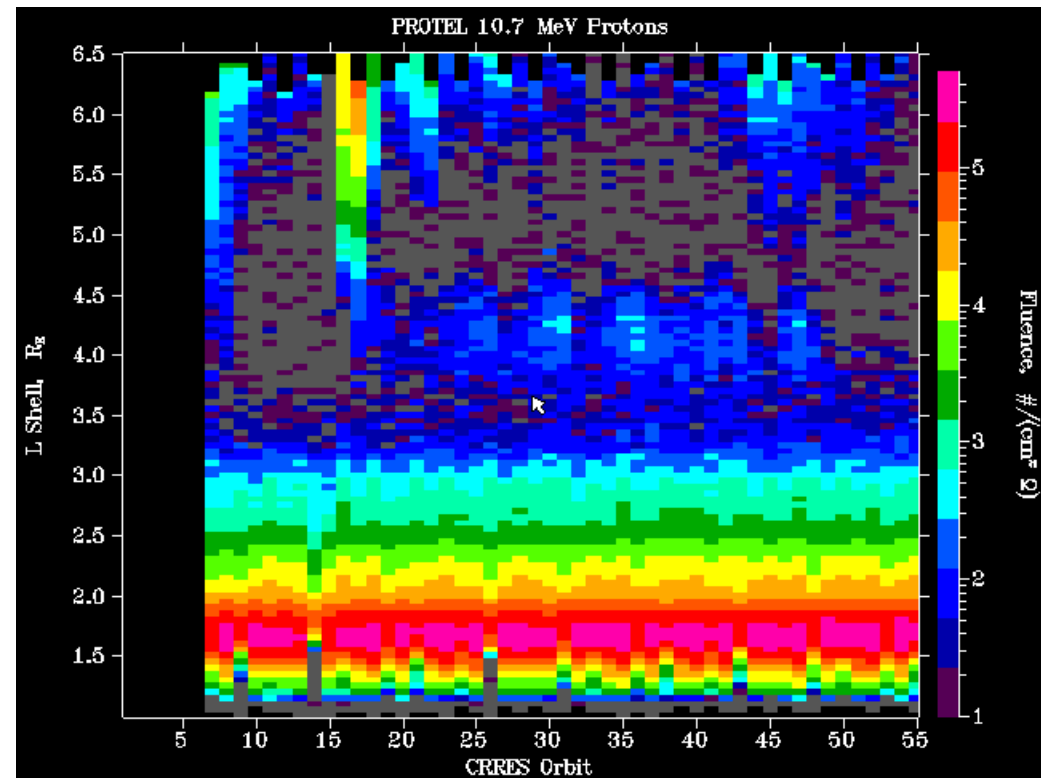

# Planetary Radiation Belt Acceleration

- Radial diffusion was once believed to be the primary acceleration mechanism at Jupiter and Saturn.
- However, it is not clear that radial diffusion can fully explain the observations.
- Diffusive and non-linear interaction with chorus waves have also been proposed to explain acceleration at the outer planets.

# Loss Mechanisms

1.0 Electron Radiation Belts at Earth

2.0 Proton Radiation Belts at Earth

3.0 Planetary Radiation Belts

**LOST  
IN  
SPACE**



- Electron Radiation Belt Loss Mechanisms:
  - Adiabatic motion due to changing magnetic field topology
  - Drift out magnetopause boundary
  - Outward radial diffusion
  - Scattering into the atmosphere (EMIC, whistler, ECH waves, stretched field)

# Adiabatic Motion

- Electrons move due to changing magnetic fields and induced electric fields causing flux decreases.
- Example: Dst effect [Dessler and Karplus, 1961; Kim and Chan, 1997]
- If the field changes slowly compared to the gyro, bounce and drift period then the motion can be described by assuming all 3 adiabatic invariants are conserved.

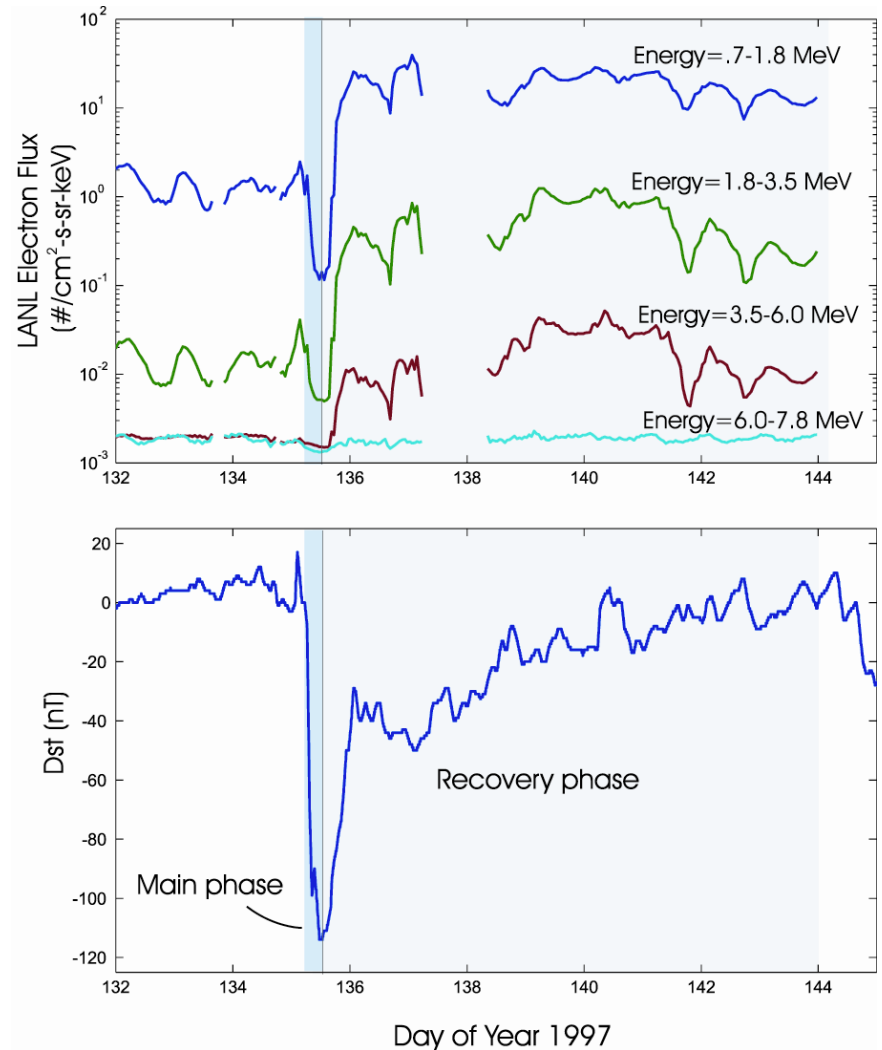

# Dst Effect/Adiabatic Flux Decrease

- 1) During the main phase the inner magnetospheric field decreases. Relativistic electrons move outward to conserve the flux invariant.
- 2) Electrons move out to a lower magnetic field region. Their energy drops to conserve  $\mu$ .

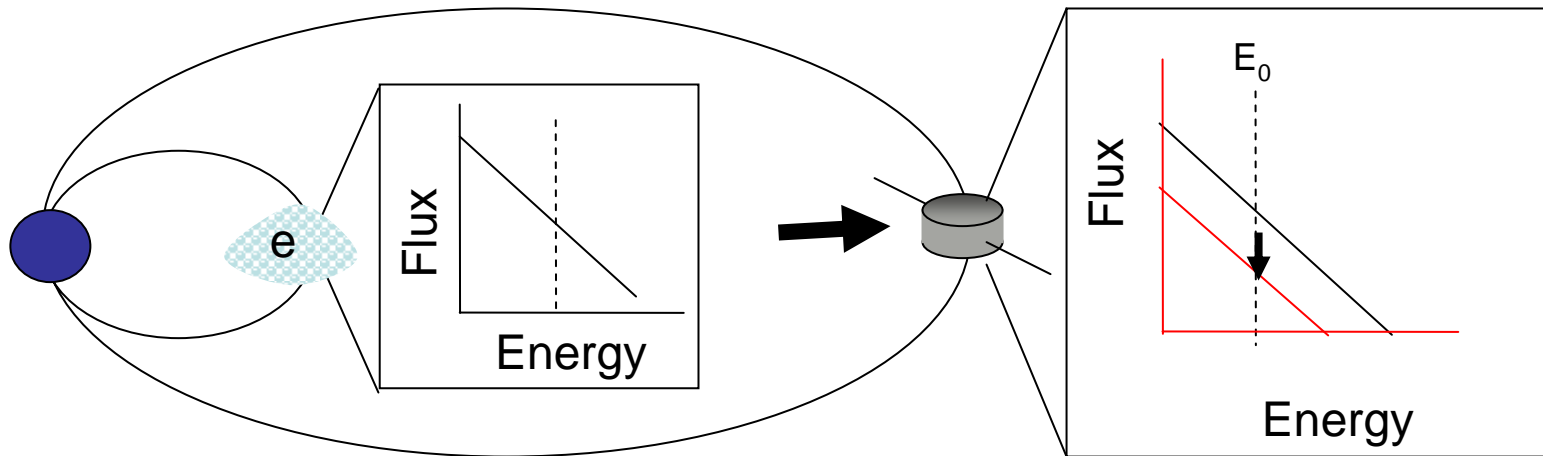

- 3) A spacecraft at fixed radial distance sampling fixed energy measures the flux of electrons previously at smaller radial distance shifted to lower energy resulting in a flux decrease.
- 4) **Adiabatic flux decreases are only apparent loss. When the field relaxes back to the prior conditions the electrons return.**

# Adiabatic Motion

- A stretched field may also produce an adiabatic flux decrease.
- Electrons conserve  $\mu$  thus following contours of constant B. The orbits are distorted in the stretched region where the field is low.
- Electrons also conserve  $\Phi$ .
- A geosynchronous satellite measuring fixed energy now samples different L and  $\mu$  values. In the low field region the satellite measures larger L and higher  $\mu$  values where flux is typically lower.

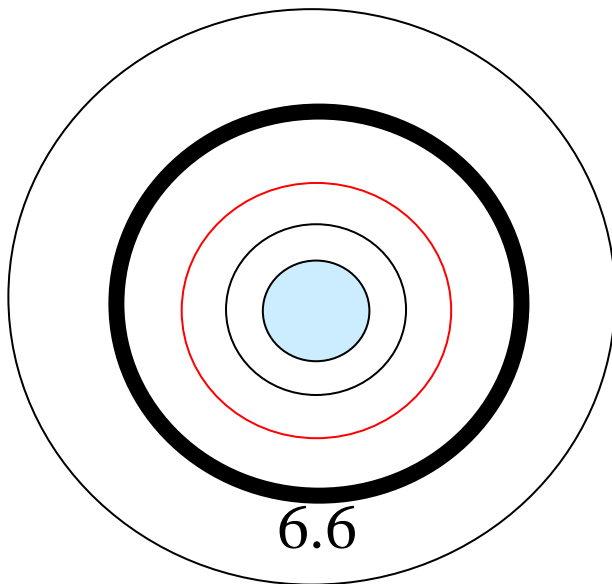

Dipole Field

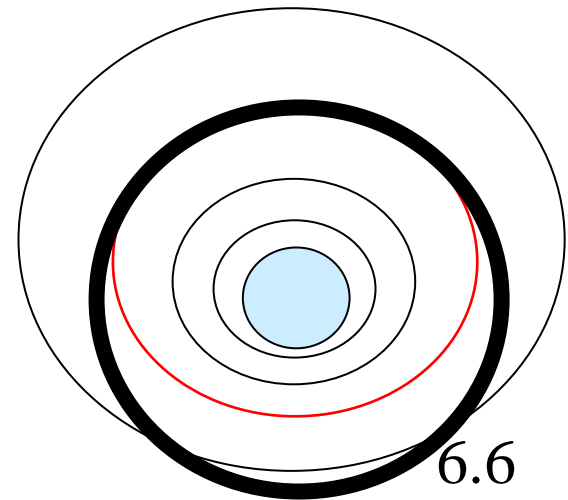

Stretched Field

# Storm time losses: Adiabatic Response

- Clearly responsible for some of the observed flux reduction during the main phase [*Kim and Chan, 1997*].
- Exact contributions are difficult to determine because estimates depend heavily on global field changes predicted by models whose accuracy is uncertain during the main phase.

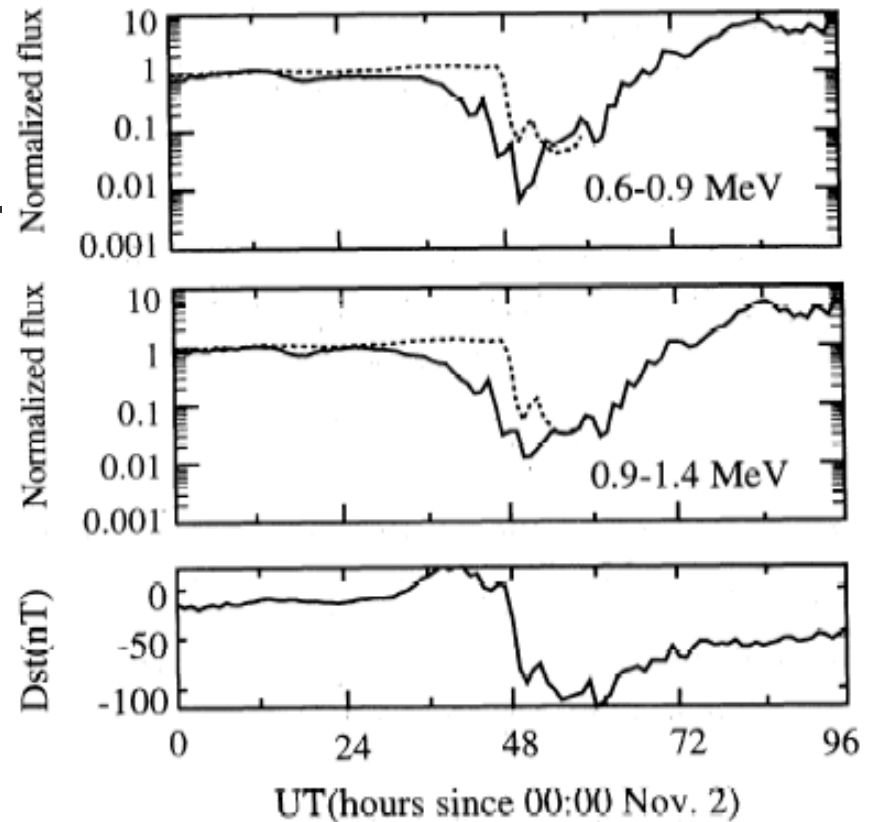



# Quiet Time Losses

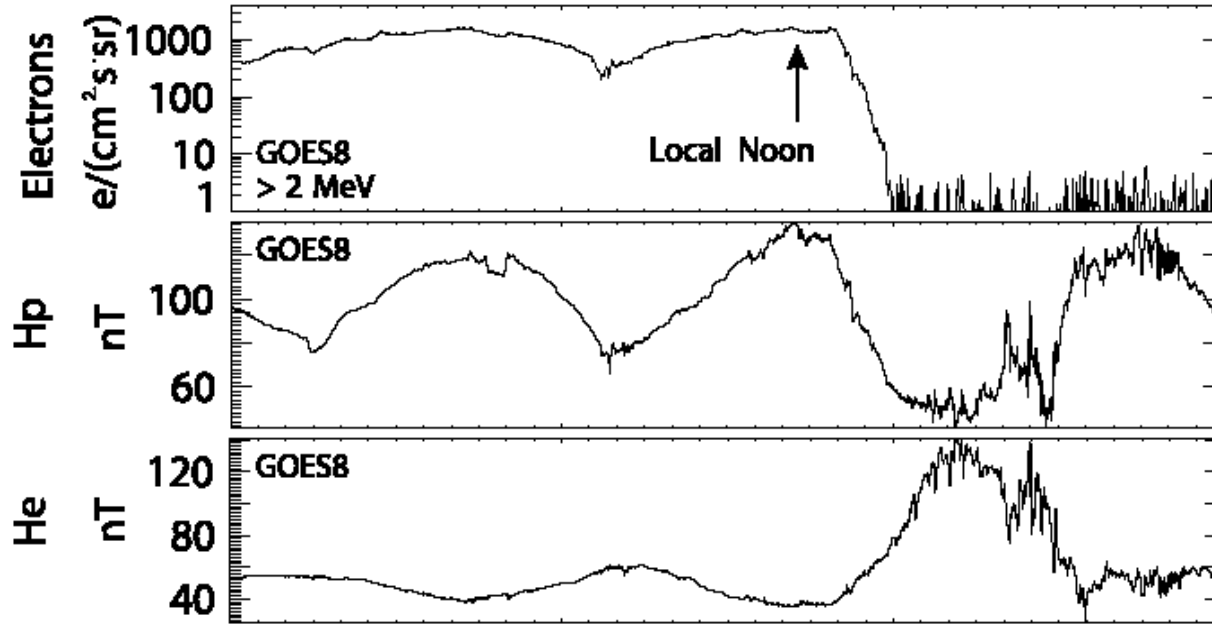

[Onsager et al., 2002]

Green et al. 2004 use a superposed epoch analysis of 52 events to investigate the 3 potential causes of the flux depletions.

- *Adiabatic electron motion*
- *Drift out the magnetopause boundary*
- *Scattering into the atmosphere*

Are flux decreases caused solely by adiabatic electron motion in response to a changing field topology?

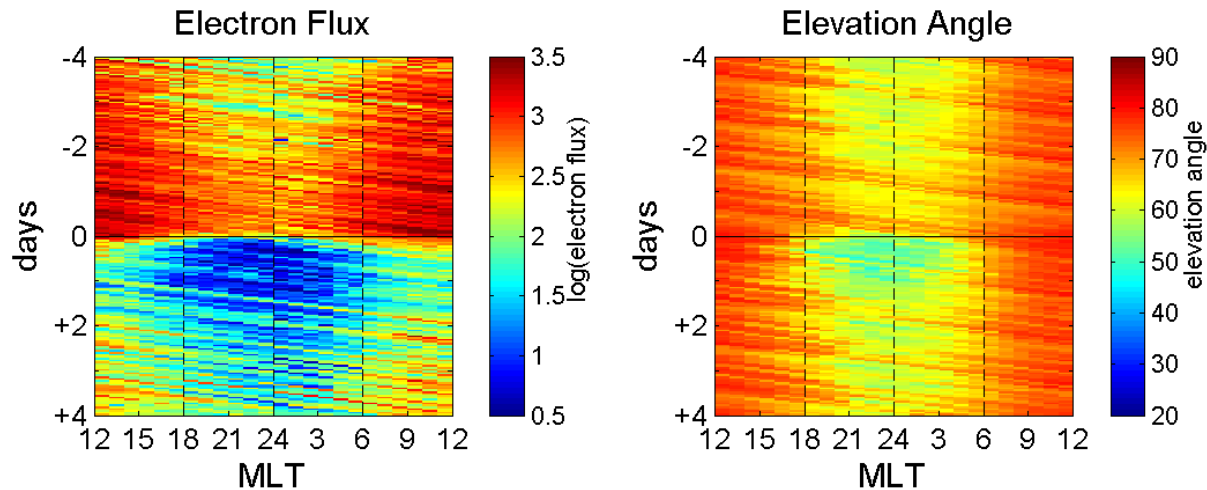

**NO.**

- Magnetic field becomes extremely stretched at dusk to midnight.
- However, the field returns to a dipolar configuration after ~1 day but the electrons do not return implying some permanent loss occurred [*Green et al., 2004*].

# Magnetopause Loss

Adiabatic motion can lead to real loss if electrons move out far enough to encounter the magnetopause.

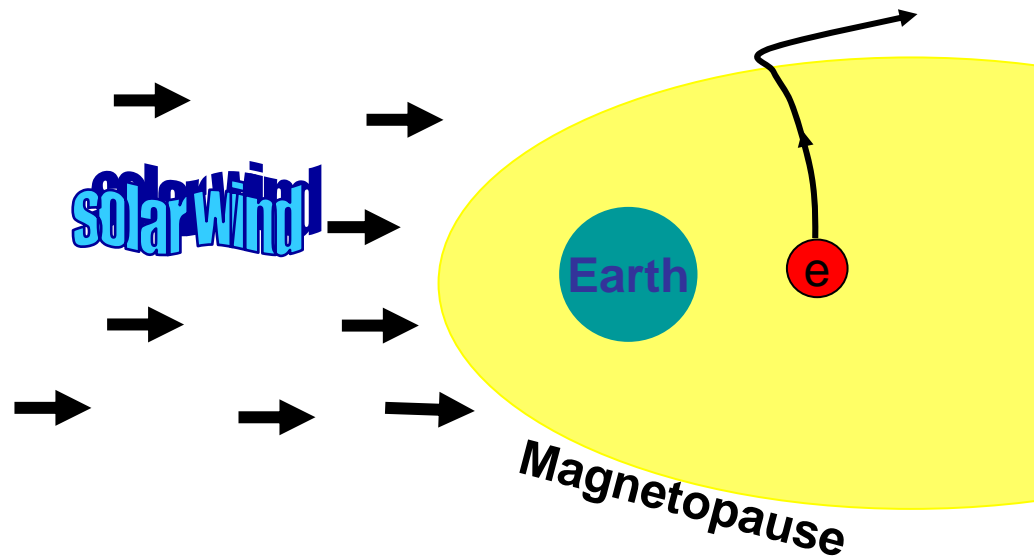

# Magnetopause Loss

*Kim and Chan [1997]*

examined one storm and based on theoretical calculations concluded that geosynchronous electrons could be pushed to the magnetopause.

Ukhorisky et al. [2006] suggests that electrons at geosynchronous can be lost to the magnetopause using expected drifts from the Tsyganenko field model.

Currently, there is no observational support favoring this loss mechanism.

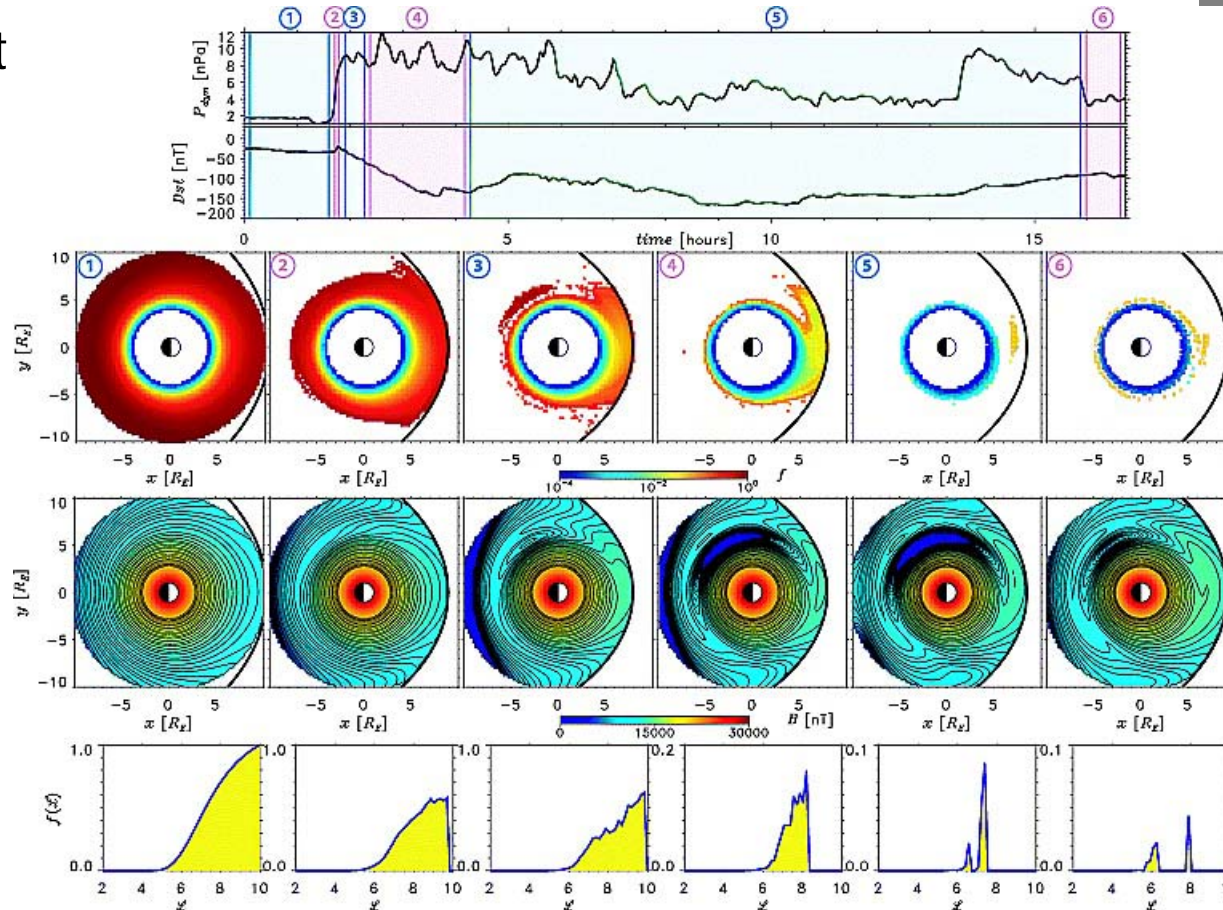

# Outward Radial Diffusion

Radial diffusion reduces gradients. A negative slope produced by a decreased source of particles in the plasma sheet can cause outward diffusion.

Electron  
phase space density

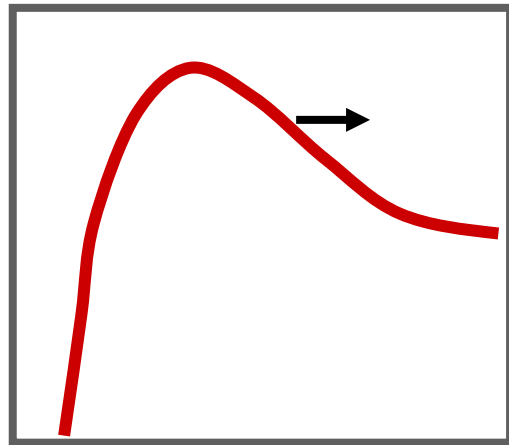

$L^*$

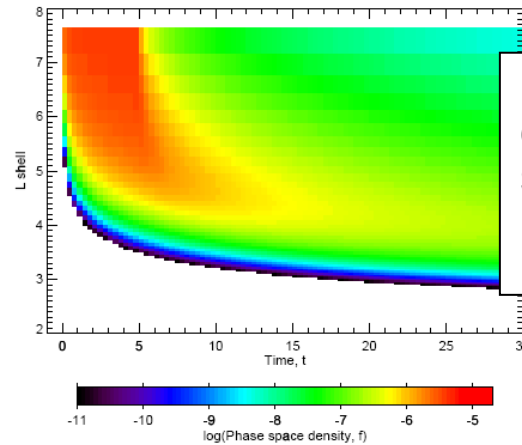

Example: Radial diffusion simulation by *Selesnick and Blake [2000]*.

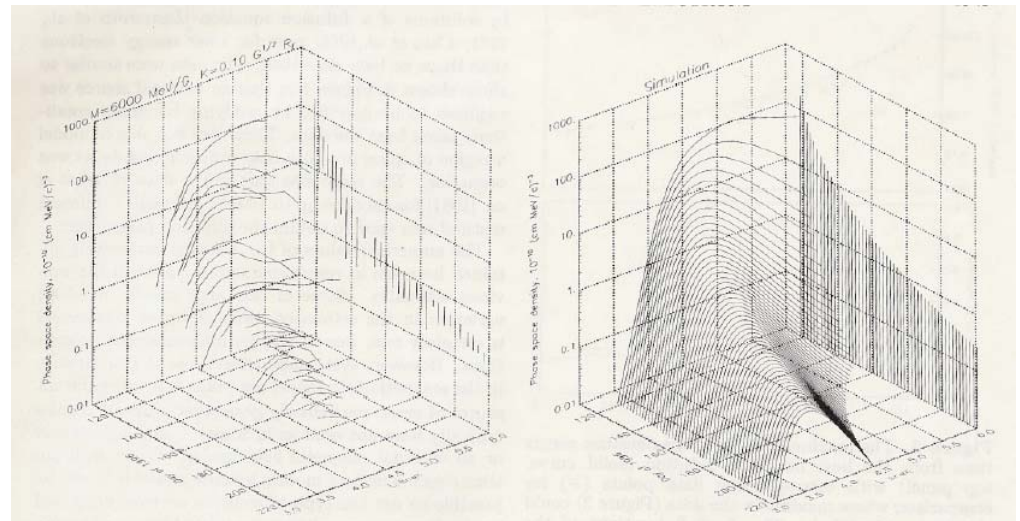

Selesnick and Blake [1997] modeled quiet time decay using a radial diffusion model with  $f=0$  at  $L=3$  and  $8$ .

# Precipitation

- Electromagnetic ion cyclotron waves (EMIC)
- Whistler waves

- 
- Scattering off stretched field

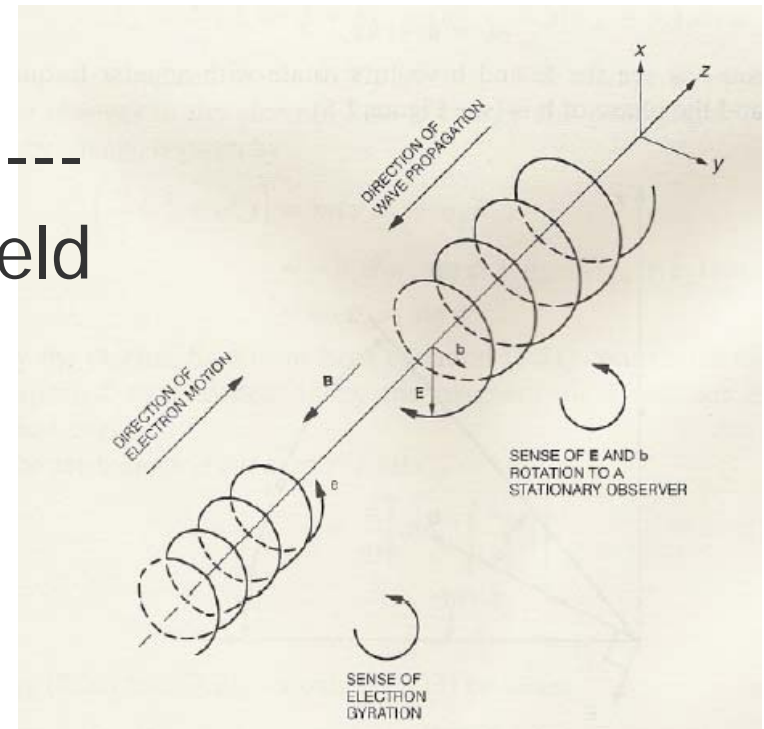

# EMIC Wave Induced Precipitation

- These waves are thought to be produced by an unstable (peaked at 90° pitch angle) ring current proton distribution.
- Electrons with the right doppler shifted gyrofrequency will interact with the wave.
- Diffusion curves describe how an electrons energy and pitch angle will change as it interacts with the wave. The diffusion curves for interaction with EMIC waves follow constant energy contours.
- The initial distribution determines the net direction of diffusion.

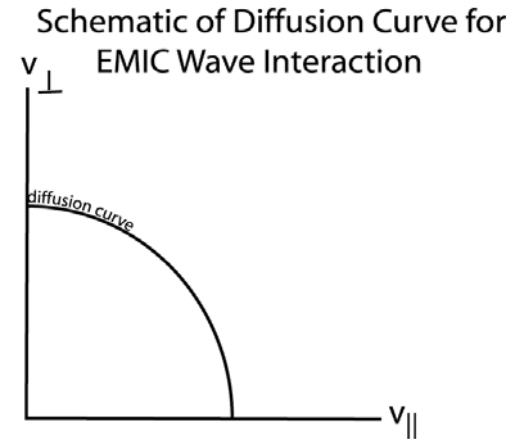

*Summers et al.* [1998] calculate diffusion curves assuming parallel propagating waves using the cold plasma dispersion relation.

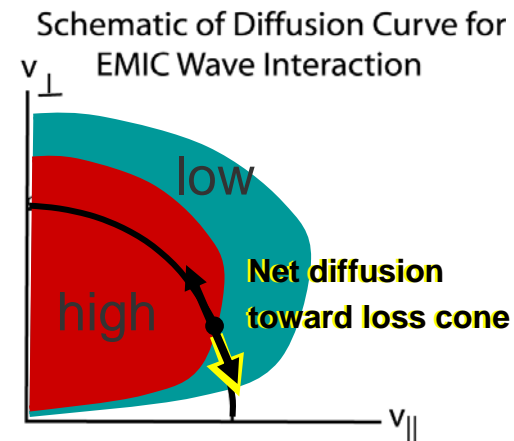



# Precipitation due to EMIC waves

EMIC event location as a function of (L,MLT)

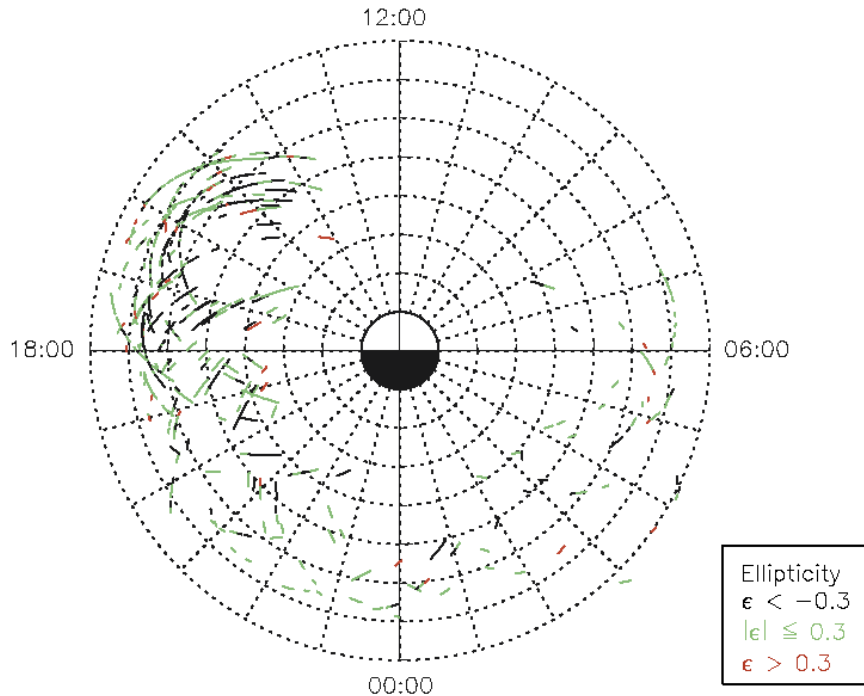

- Theoretically, EMIC waves can very efficiently scatter electrons into atmosphere with little energy change [*Horne et al.*, 1998] .
- 5-10 hour bounce averaged lifetimes [*Albert*, 2003].
- Waves observed near dusk where proton drift paths cross high density plasma plumes [*Meredith et al.*, 2002, *Fraser et al.*, 2004].
- High density is required to bring the resonant energy down to the MeV range [*Meredith et al.*, 2002]



# Precipitation due to EMIC waves?

- No clear observational connection between EMIC waves and precipitation.
- There is some speculation that MeV precipitation observed by balloons [*Millan et al.*, 2002] and possibly bands [*Nakamura et al.*, 2000; *O'Brien et al.*, 2004; *Imhof et al.*, 1996] are caused by interaction with EMIC waves.

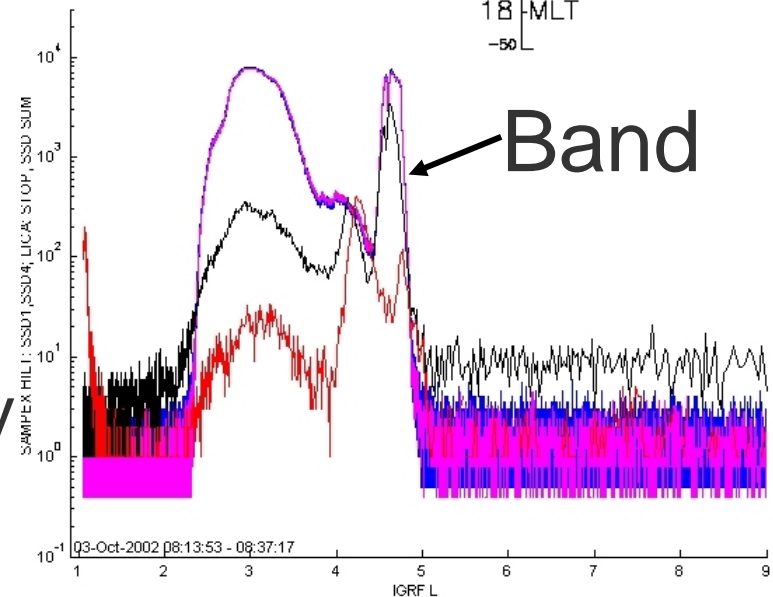
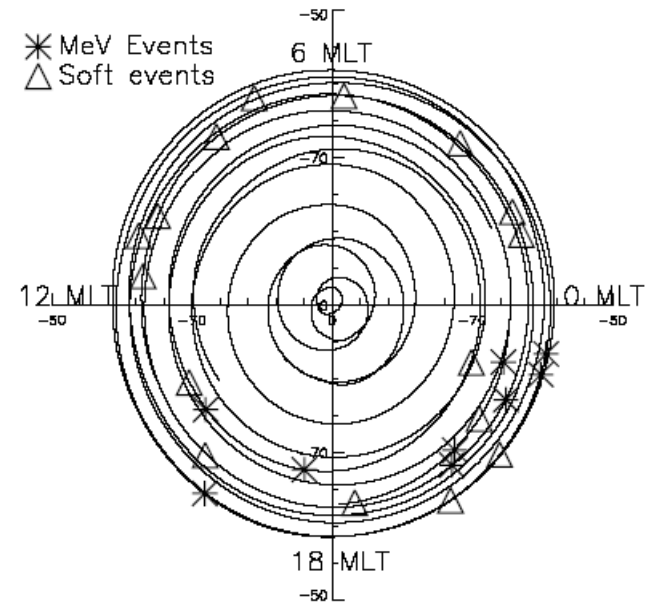

# Precipitation due to whistler waves

- Whistlers are thought to be produced by unstable (peaked at 90) distributions of substorm injected low energy (keV) electrons.
- Whistlers scatter relativistic electrons while also changing their energy [*Horne et al.*, 1998; *Summers et al.*, 1998].
- Electrons scattered towards 90 degrees gain energy. Those scattered towards the loss cone lose energy.
- The initial distribution determines the net direction of diffusion.

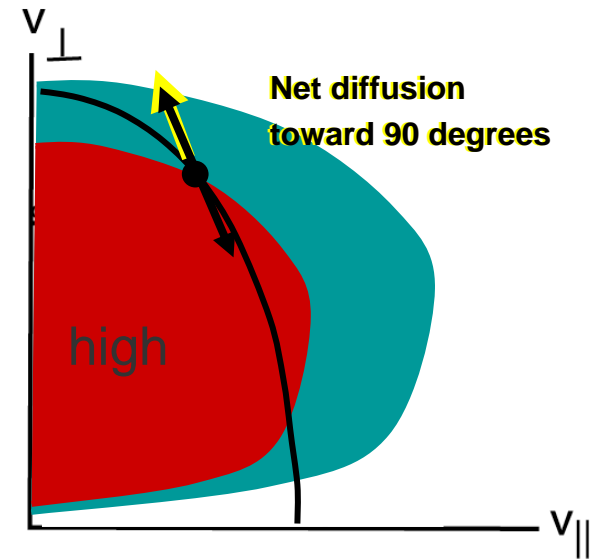

# Precipitation due to whistler chorus

Equatorial Lower-Band Chorus and MeV Microbursts, Kp 4-6

## Microburst Occurrence Frequency

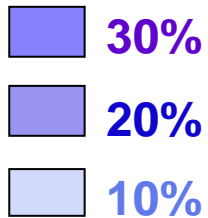

Dusk

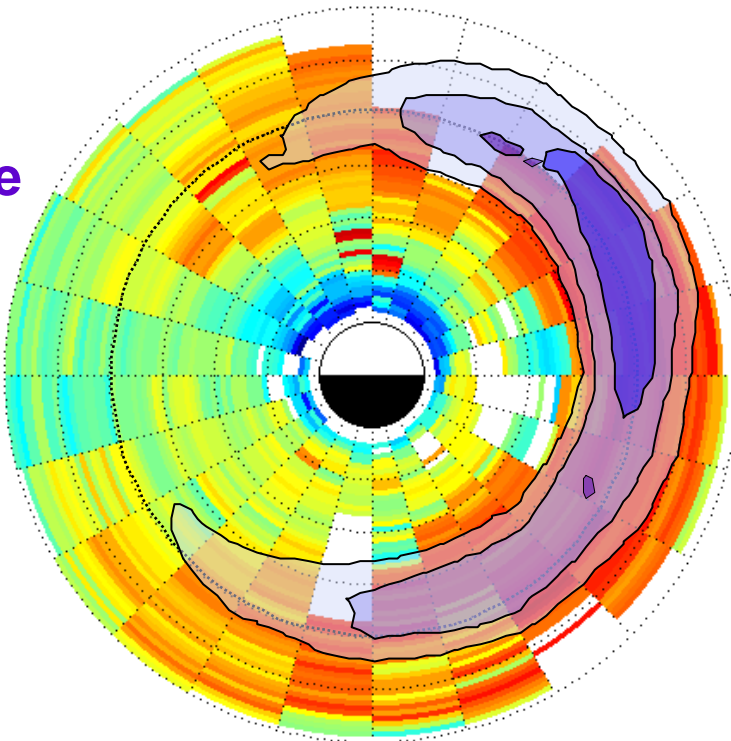

Midnight

Dawn

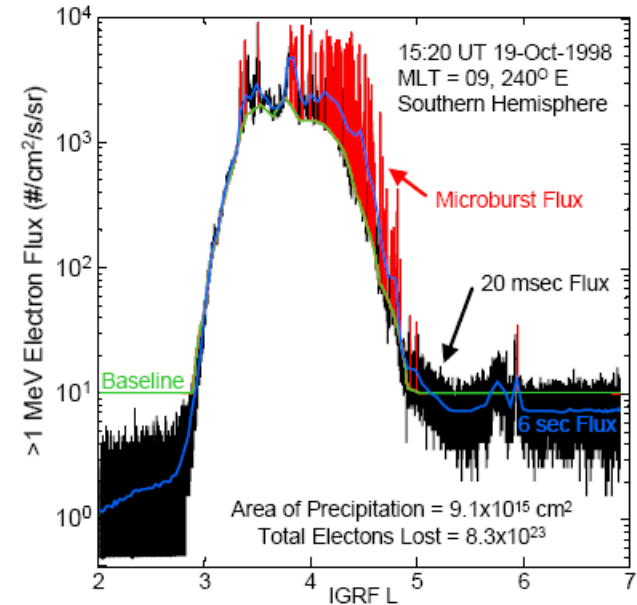

- Chorus and bursty MeV electron precipitation seen by SAMPEX are both observed at dawn [O'Brien et al., 2003; Nakamura et al., 2000; Lorentzen et al., 2000].
- Chorus risers and microbursts last for the same time [Lorentzen et al., 2000].
- Individual Chorus risers from Polar have been correlated with microbursts observed at low altitude by SAMPEX [Lorentzen et al., 2000].
- Resonant energy calculations for given plasma and field conditions suggest that observed waves will interact with MeV electrons [Lorentzen et al., 2000].

# Scattering due to stretched field

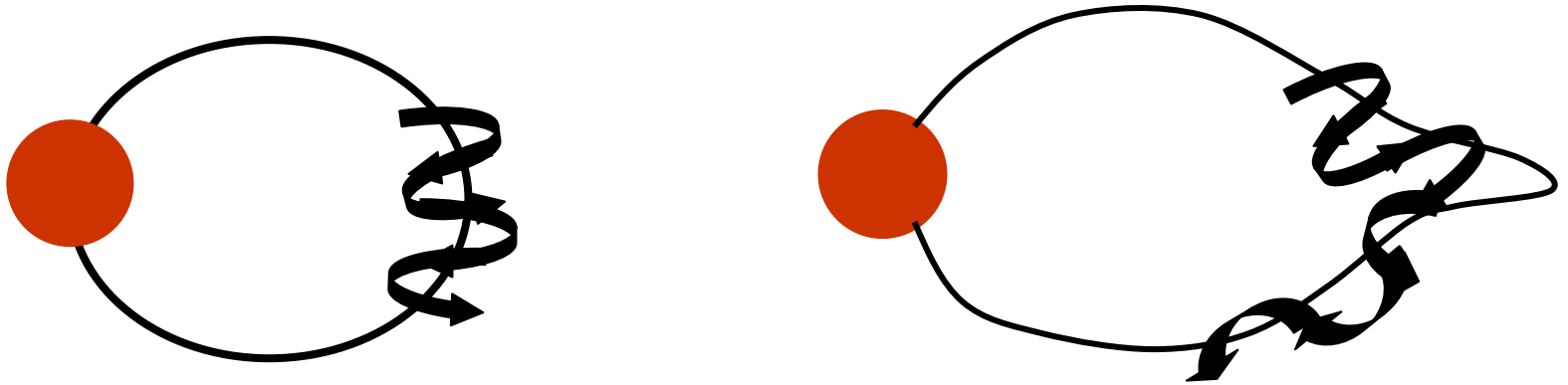

Electrons are scattered when the radius of curvature of the magnetic field is comparable to the gyroradius.

# Scattering due to stretched field

Higher energy particles will scatter at smaller  $L$  where the field is less kinked because they have larger gyroradii. In agreement with this theory *Imhof* [1977] observed that isotropy energies decreased with  $L$ .

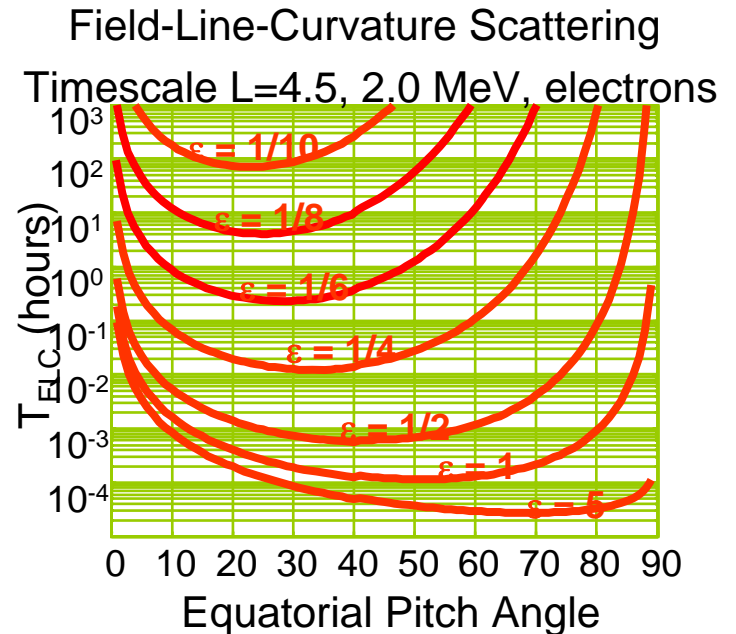
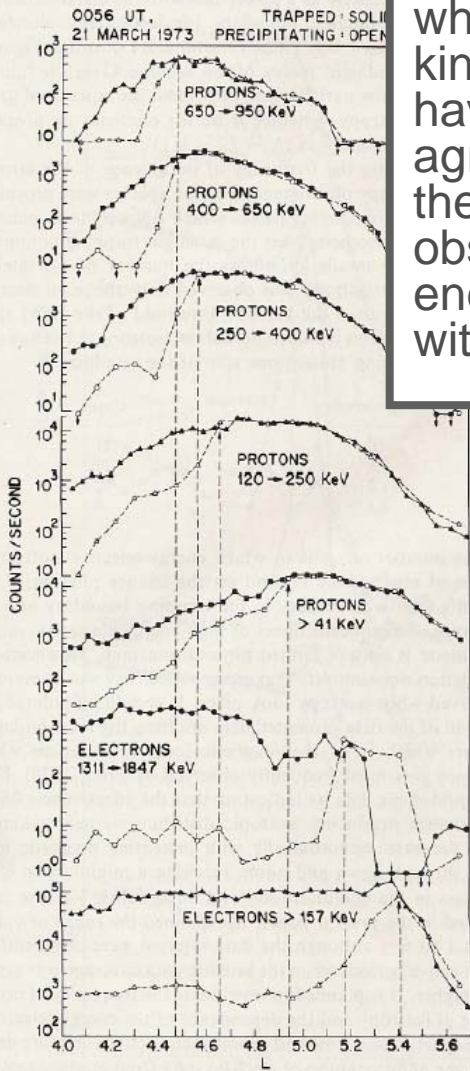

Paul O'Brien sampled  $\epsilon = R_{gyro}/R_c$  in the T89, T96 and T01 models three days either side of observed electron flux decreases at geosynchronous. Only three points in the T89 model reached  $\epsilon = 1/10$  corresponding to a lifetime of  $\sim 100$  hours.

# Proton Radiation Belt Losses

- Scattering due to kinked field line.
- EMIC wave interaction.
- *Lorentzen et al. [2002]*, analyzed a large variety of data during a 2 year period and found no consistent description concluding that 'many questions remain to be answered, and it may be that more than one mechanism plays a role in each event.'

# Planetary Radiation Belt Losses

- Moons provide a source of loss.
- If radial diffusion timescales are slower than the orbit of a moon, then the moon creates a barrier inside of which particles can't penetrate.

# Models

1.0 Empirical/Statistical

2.0 Physics Based

3.0 Data Assimilation

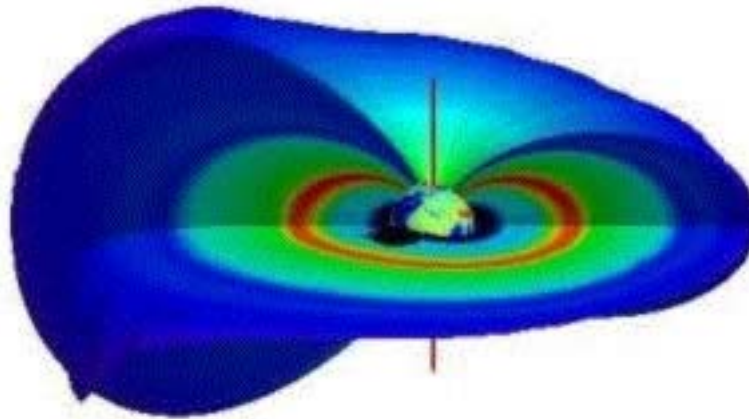



# Empirical/Statistical Modeling Solutions

- Climatology: Used as the first line of defense to determine shielding.
  - AP8/AE8 provides average particle flux during solar min/max [Vette, 1991].
  - CRRESELE provides average particle flux.

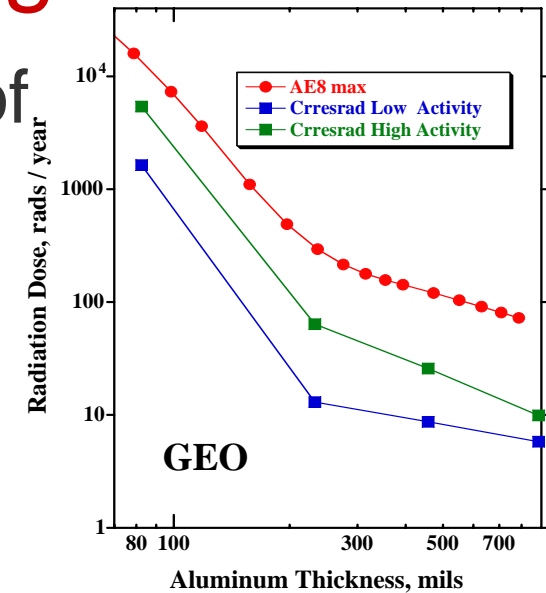

## Significant deficiencies have been identified in AP and CRRESELE

- Living with a Star NASA funded project headed by Aerospace Corp. to include more recent satellite data and provide probability distributions of particle flux as a function of solar cycle phases and month.

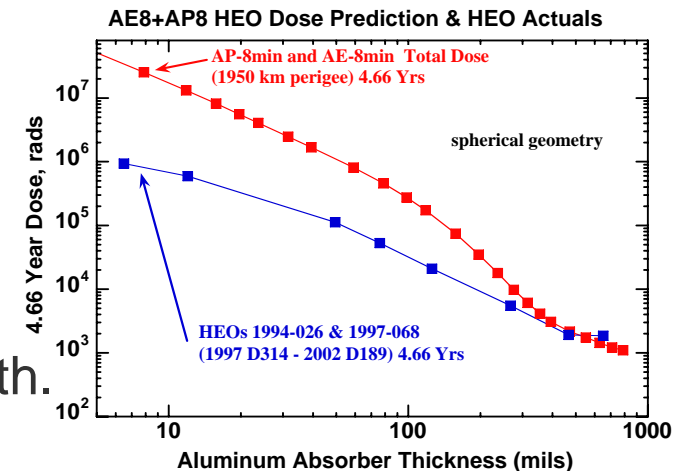

# Empirical/Statistical Modeling Solutions

Nowcast/Forecast: Electron flux nowcasts provide situational awareness for analyzing satellite upsets while forecasts provide the ability to prepare for potential upsets.

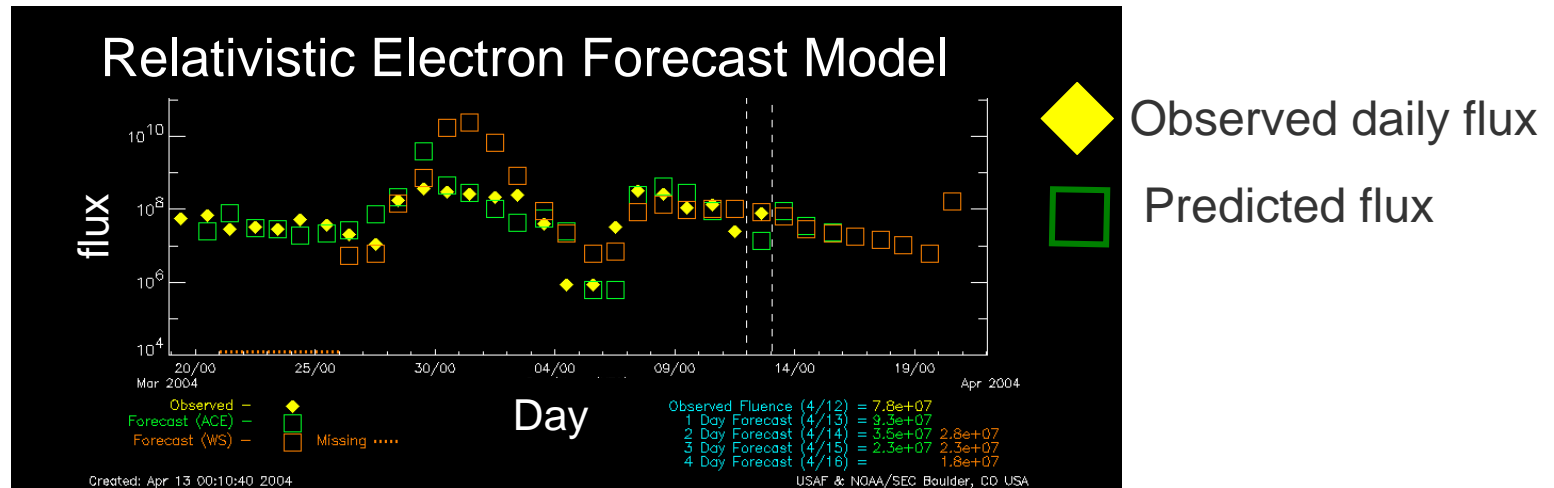

- **REFM**: predicts flux at geosynchronous
  - 1day PE=80%, 2day PE=-24%, 3day PE=-49%
- **Statistical Asynchronous Regression**: specifies geosynchronous flux at any local time based on a measurement at one local time.
- **State space model with Kalman filter**: predicts flux at low altitude based on previous SAMPEX measurements.

# Physics Based Modeling Solutions

- Nowcast/Forecast Models:
  - Particle tracing in MHD fields
    - CISM model [*Elkington et al.*, 2004]
  - Radial diffusion with parameterized loss
    - Solar wind parameterized model [*Li et al.*, 2005]
    - UCLA model [*Shprits et al.*, 2004]
  - Convection with radial diffusion and loss due to wave scattering
    - RAM model [*Miyoshi et al.*, in press]
  - Convection with radial, energy, pitch angle diffusion and loss due to wave scattering
    - Salambo model [*Bourdarie et al.*, 2005]
    - AFRL model

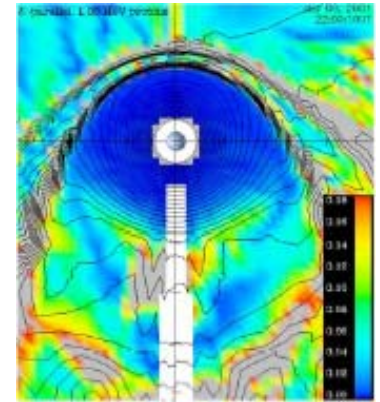

*Information about relevant physics to include, quantitative estimates of outer/inner boundary conditions, and wave power/locations are needed to constrain these models.*

# Combined Empirical and Physical Modeling Solutions

## Nowcast/Forecast Models:

- Radial diffusion model with no losses updated with Kalman filter [*Naehr and Toffoletto.,2005*]
- Salambo model: Convection with radial diffusion and loss due to wave scattering updated using a technique that directly inserts measured data [*Bourdarie et al., 2005*].
- LANL DREAM Model: Radial diffusion model that includes Kalman Filter

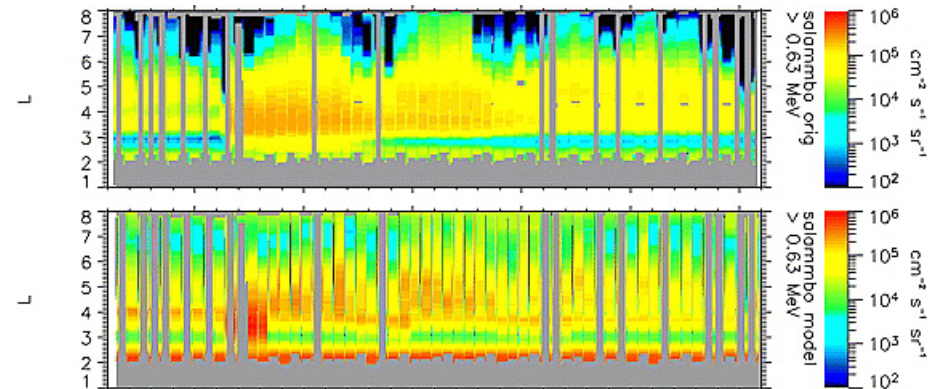
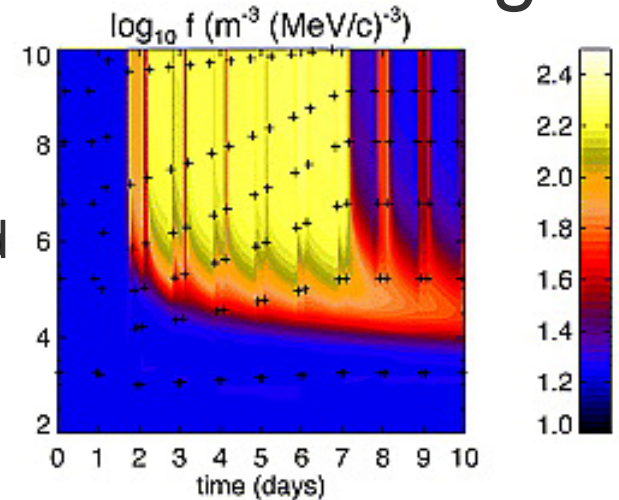

## Highlights:

- 1) Underlying physics dictates the time resolution and location of measurements required for data assimilation models to be accurate.
- 2) A more accurate physical model produces more accurate results.

# Summary

- While basic questions still remain about the acceleration and loss of radiation belt particles much has been learned since their discovery.
- The physics learned and applied in new models is benefiting society in tangible ways.

the 1990s, the number of people in the UK who are aged 65 and over has increased from 10.5 million to 13.5 million, and the number of people aged 75 and over has increased from 4.5 million to 6.5 million (Office for National Statistics 2000).

There is a growing awareness of the need to address the needs of older people, and the need to ensure that the health care system is able to meet the needs of older people. The Department of Health (2000) has published a strategy for older people, which sets out the government's commitment to improve the health and well-being of older people.

The strategy for older people is based on the following principles:

- To ensure that older people have the opportunity to live as long and as healthy a life as possible.
- To ensure that older people have the opportunity to live in their own homes and communities.
- To ensure that older people have the opportunity to participate in social and community activities.
- To ensure that older people have the opportunity to live in a safe and secure environment.

The strategy for older people is a key document for the health care system, and it sets out the government's commitment to improve the health and well-being of older people.

The strategy for older people is based on the following principles:

- To ensure that older people have the opportunity to live as long and as healthy a life as possible.
- To ensure that older people have the opportunity to live in their own homes and communities.
- To ensure that older people have the opportunity to participate in social and community activities.
- To ensure that older people have the opportunity to live in a safe and secure environment.

The strategy for older people is a key document for the health care system, and it sets out the government's commitment to improve the health and well-being of older people.

The strategy for older people is based on the following principles:

- To ensure that older people have the opportunity to live as long and as healthy a life as possible.
- To ensure that older people have the opportunity to live in their own homes and communities.
- To ensure that older people have the opportunity to participate in social and community activities.
- To ensure that older people have the opportunity to live in a safe and secure environment.

The strategy for older people is a key document for the health care system, and it sets out the government's commitment to improve the health and well-being of older people.

The strategy for older people is based on the following principles:

- To ensure that older people have the opportunity to live as long and as healthy a life as possible.
- To ensure that older people have the opportunity to live in their own homes and communities.
- To ensure that older people have the opportunity to participate in social and community activities.
- To ensure that older people have the opportunity to live in a safe and secure environment.

# Electron Radiation Belt Hazards

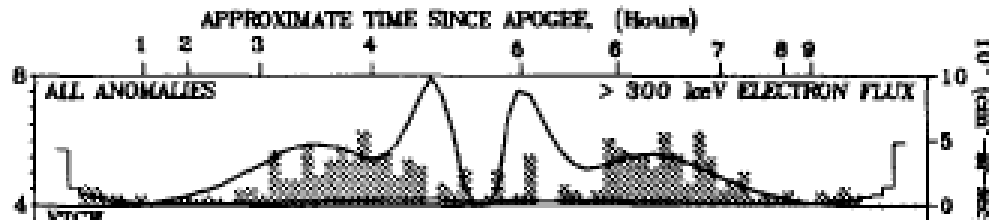

[Violet and Frederickson, 1993]

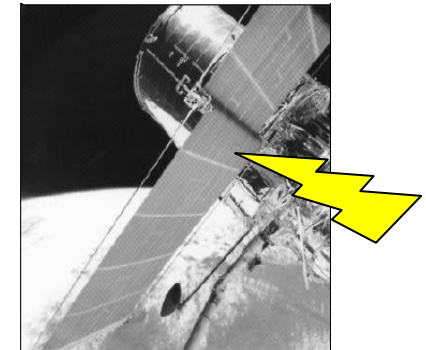

- High energy electrons can penetrate through shielding causing internal charge to build up.
- A sudden discharge may temporarily flip bits or permanently damage electronics as in the loss of the Telestar satellite.

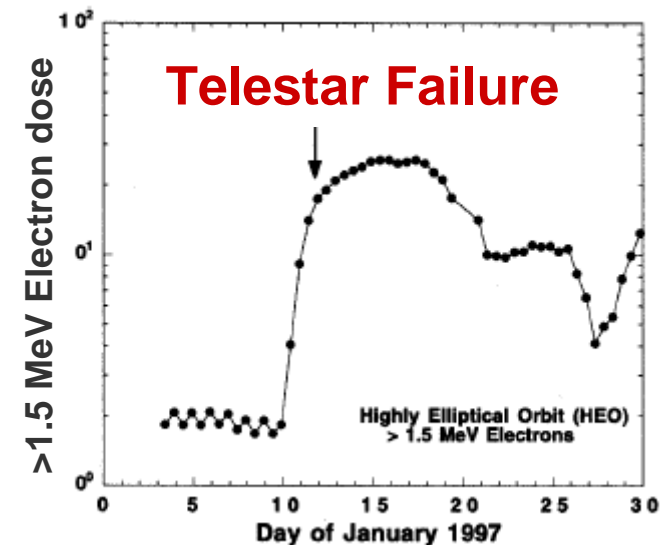

# The Challenge to Modelers

- Relativistic electron flux is extremely variable.
- Flux may increase or decrease on rapid timescales of less than one day.

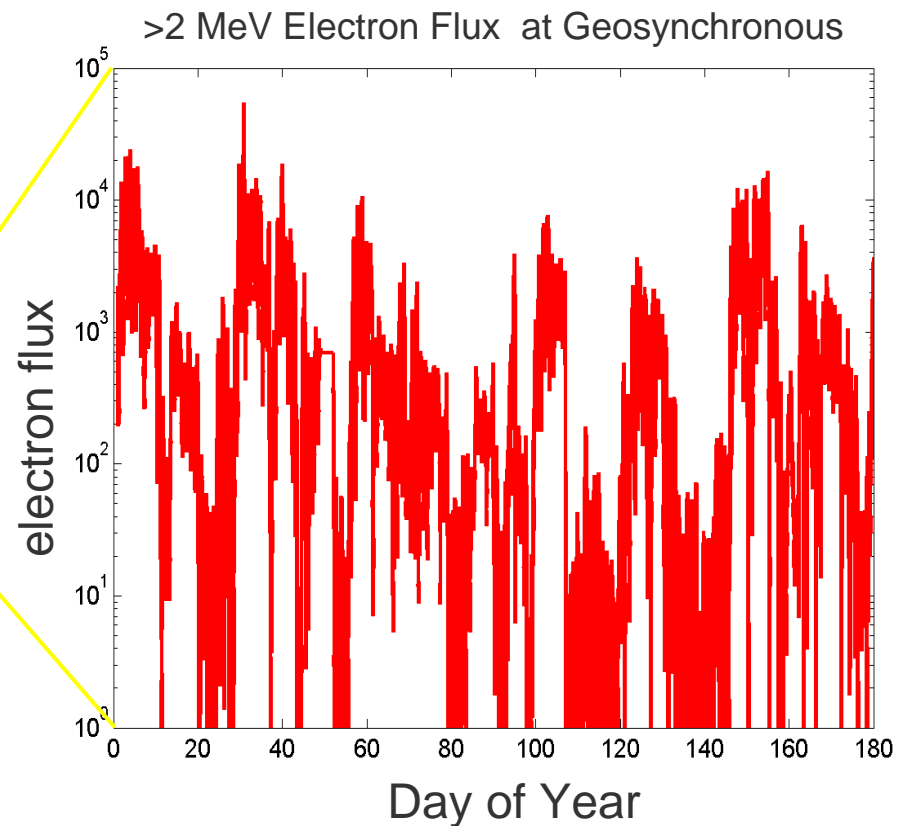
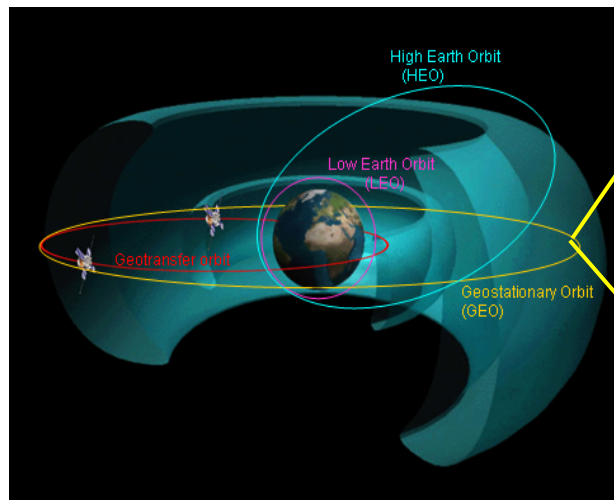



Contrary to intuition,  
relativistic electron  
flux does not always  
increase during  
geomagnetic storms  
[*Reeves et al., 2003*]

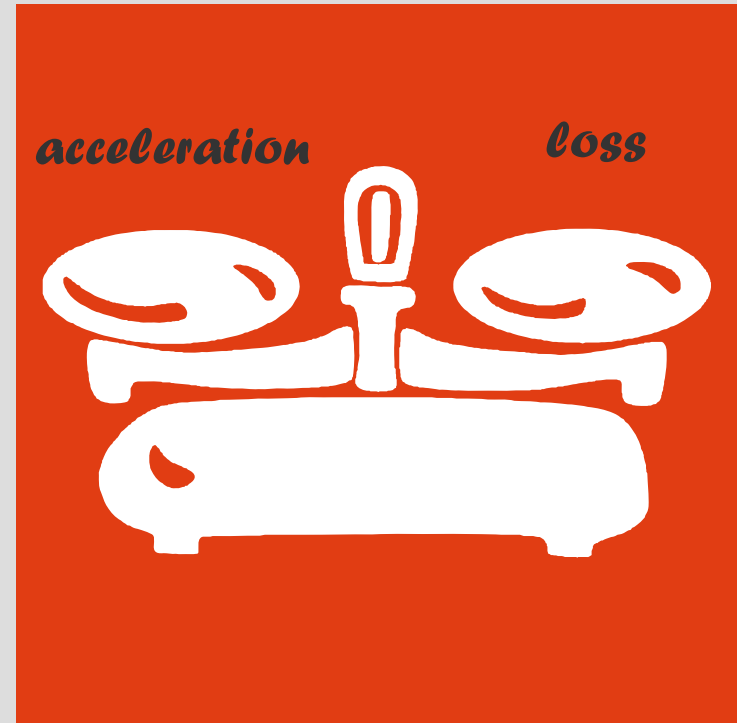

The erratic flux changes induced by geomagnetic activity suggest that acceleration processes are often countered by profuse loss.

Thus, to predict flux variations both processes must be understood.

# Analysis: Flux Depletions

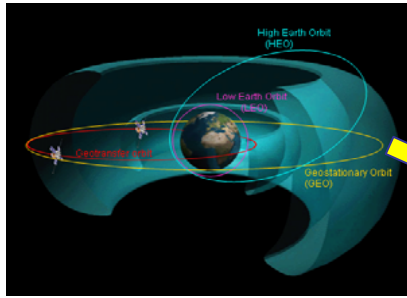

Geosynchronous flux drop-out event

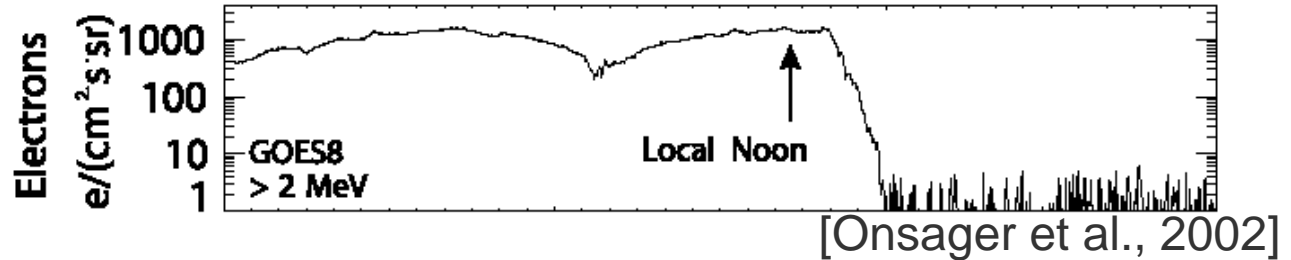

We use a superposed epoch analysis of 52 events to investigate the 3 potential causes of the flux depletions.

- ~~Electron motion in response to changing magnetic field~~
  - Magnetic field stretches then becomes dipolar again after ~1 day but the electrons do not return implying some permanent loss occurred [Green et al., 2004].
- ~~Drift out the magnetopause boundary~~
  - Polar .7-7MeV electron flux is depleted into  $L^*=4$ , much lower than the expected magnetopause.
  - GOES and HEO data show no decrease of the flux of high energy protons that follow similar drift paths that should also encounter the magnetopause [Green et al., 2004].
- *Scattering into the atmosphere*

# Are the electrons scattered into atmosphere?

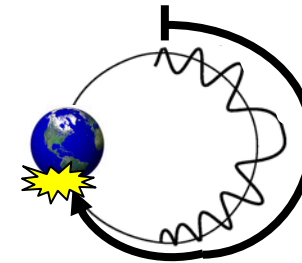
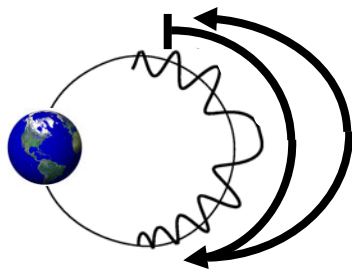
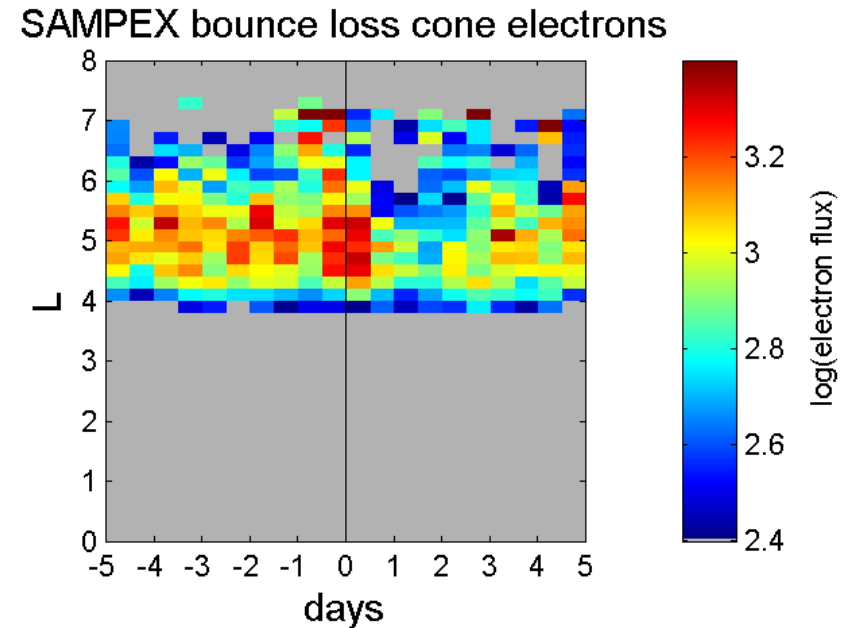
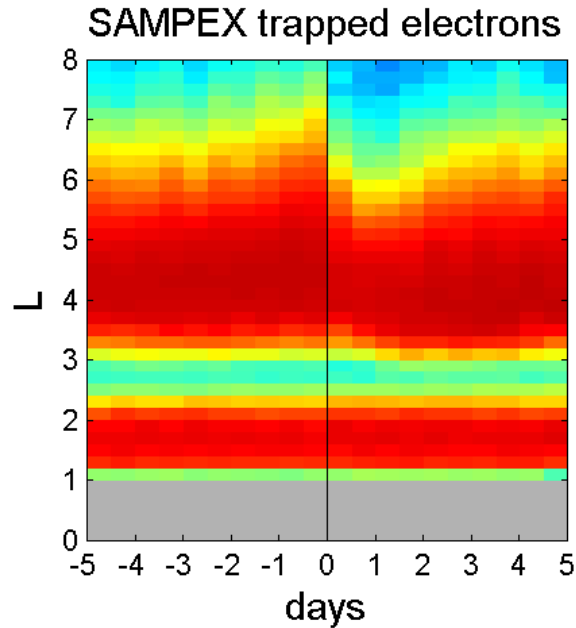

**Yes**, SAMPEX  $> 400$  keV electron data shows increased flux in the bounce loss cone within .5 days.

## What caused the scattering?

- ~~Stretched field (timescales are too slow)~~
- Interaction with electromagnetic ion cyclotron (EMIC) waves
- Interaction with whistler waves

## How can we differentiate between these?

- Observe the waves.
- Compare the local time of the precipitation and the local time of the waves.

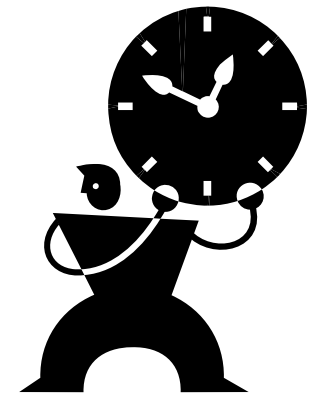

# EMIC waves

Median Wave Power .1-1 Hz hn component

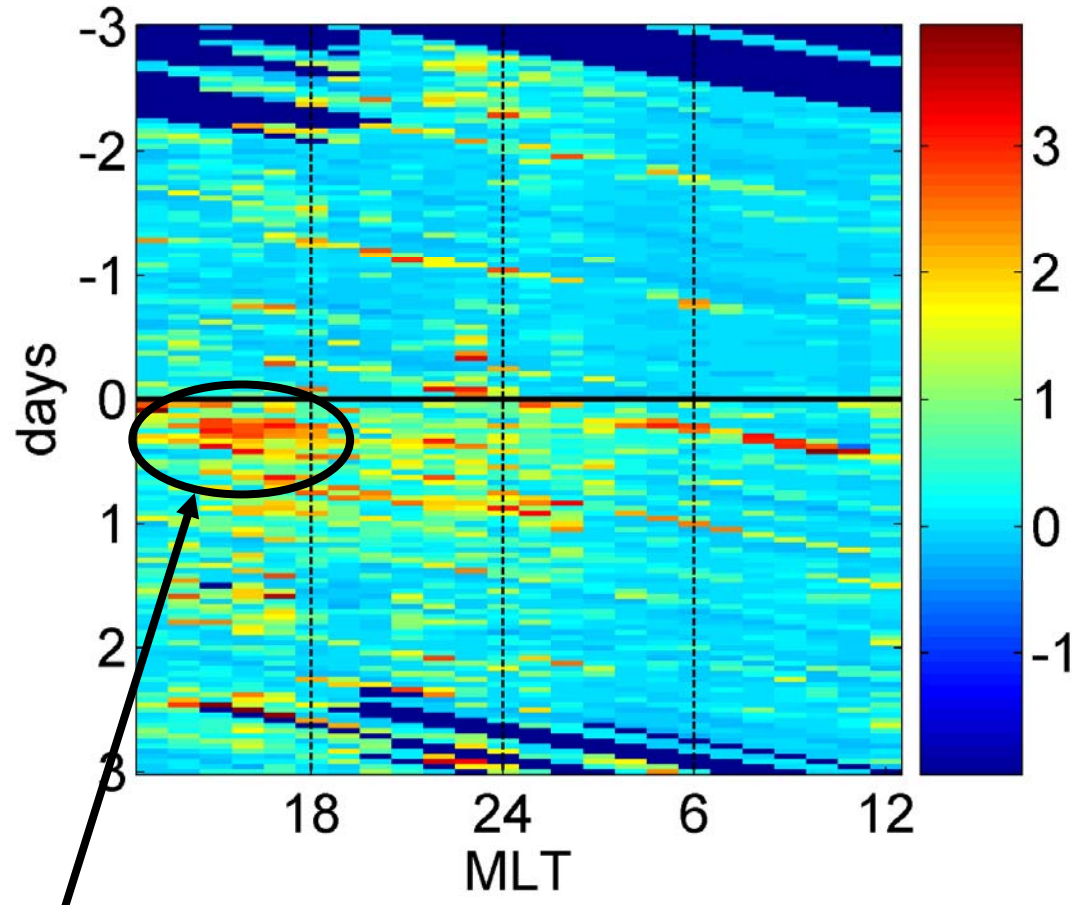

GOES geosynchronous magnetometer data shows elevated wave power from .1-1 Hz consistent with EMIC waves at 13-18 MLT.

# LANL geosynchronous plasmasphere density

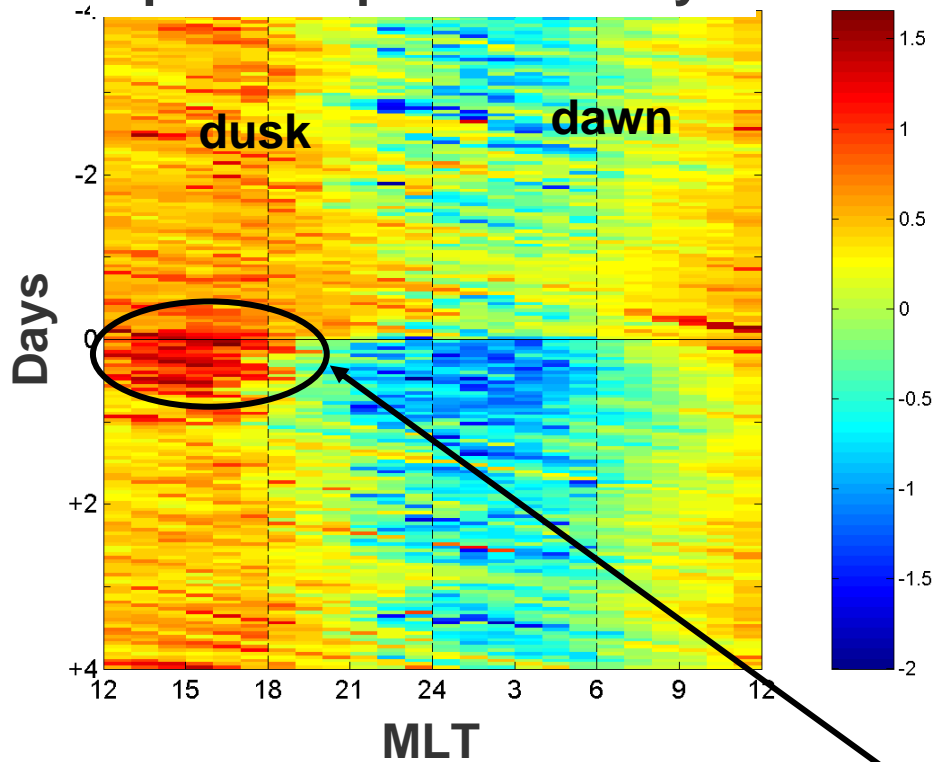

# EMIC waves

- EMIC waves scatter electrons at the resonant energy which depends on the magnetic magnitude and plasma density,  $n$ . High  $n$  is needed for these waves to scatter MeV electrons.
- High density plumes are indeed observed during the first day of the events from 12-18 MLT.

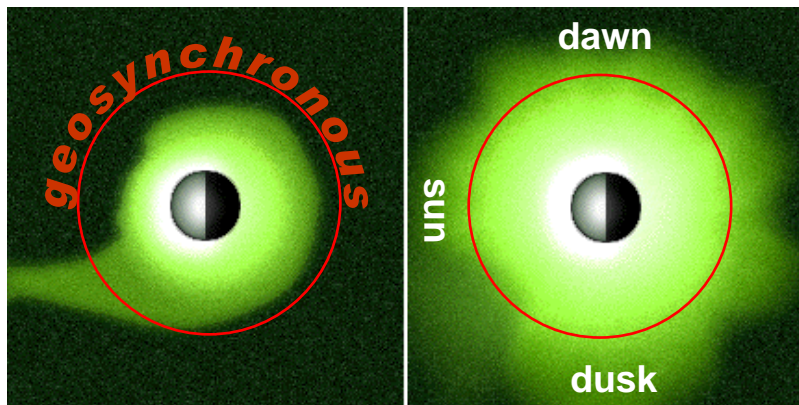

Plasmasphere schematic

# Whistler chorus

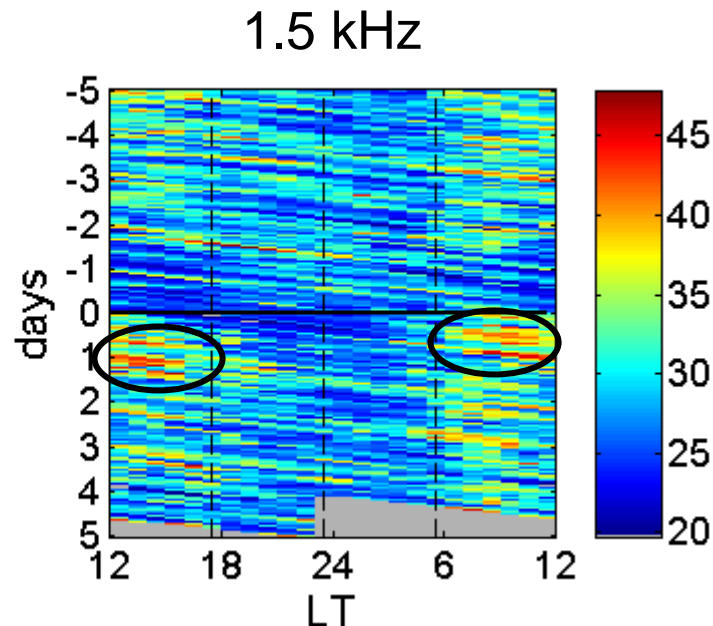
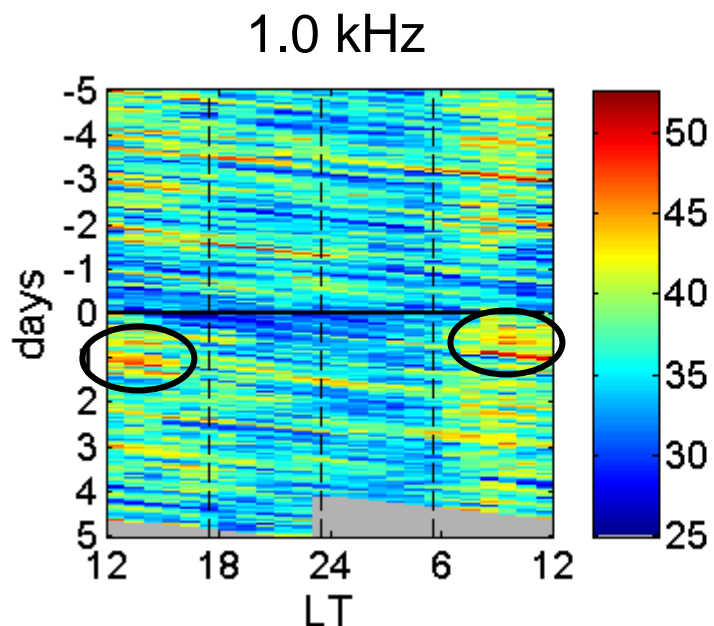

Halley bay wave measurements show increased power at chorus frequencies in the noon region (8-16 LT) similar to statistical plots of high latitude chorus from CRRES [*Meredith et al., 2001*].

Equatorial Chorus Wave  
Amplitudes  $AE > 300$  (CRRES)

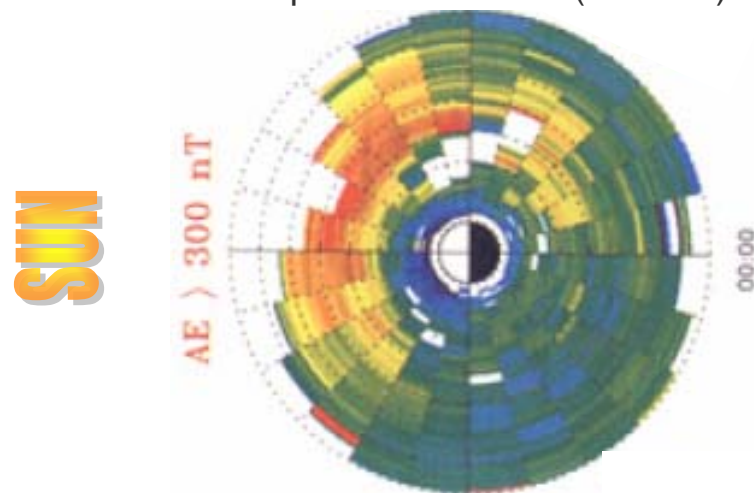

# Schematic Wave Locations

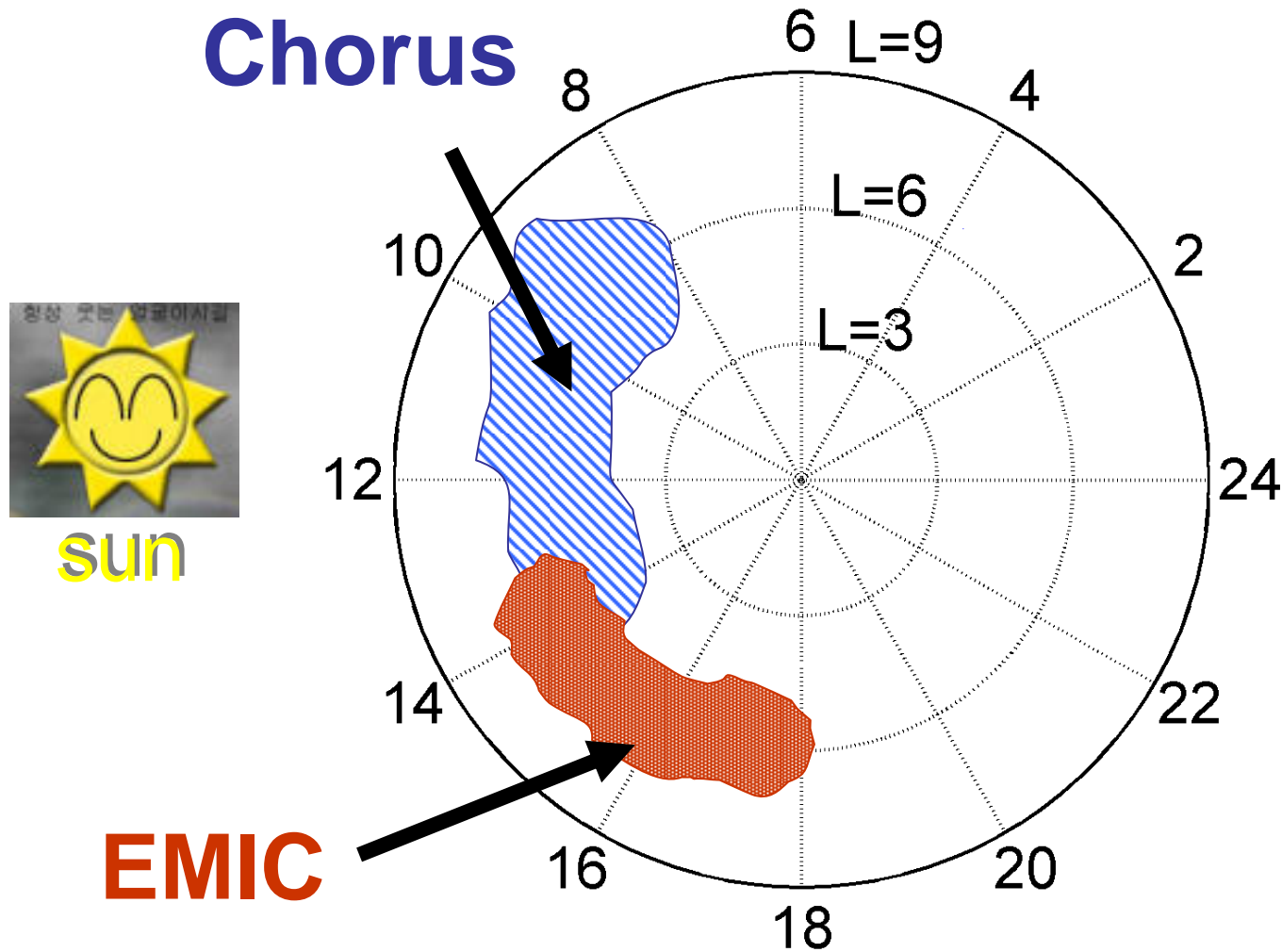





# Identifying the Local Time of Electron Precipitation

- The POES satellites measure  $>300$  keV electrons in 2 directions, ~along the field and perpendicular.



- 5 satellites orbited during the time frame of the drop out events from 1996-2004.

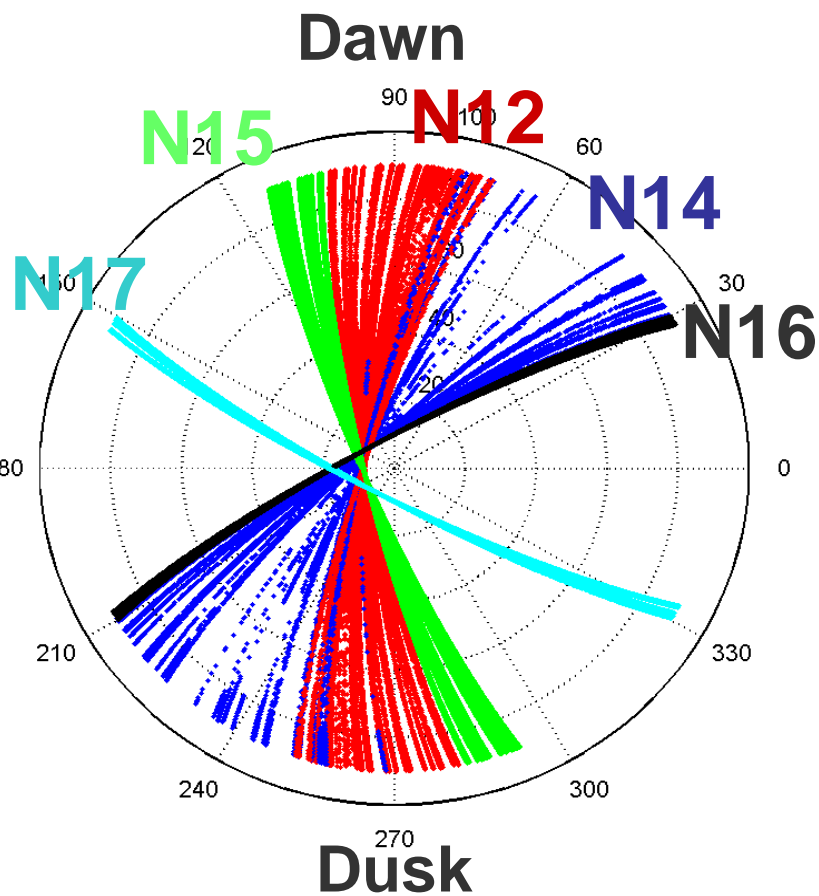



## Caution

- The time coverage of the satellites varies.
- The POES electron detectors also measure  $\sim >100$  keV protons.
- The electron fluxes may be corrected by subtracting the measured proton flux.
- We have developed a method to remove the proton contamination but the accuracy of the data is still uncertain.



# Local Time of Scattered > 300 keV Electrons Corrected

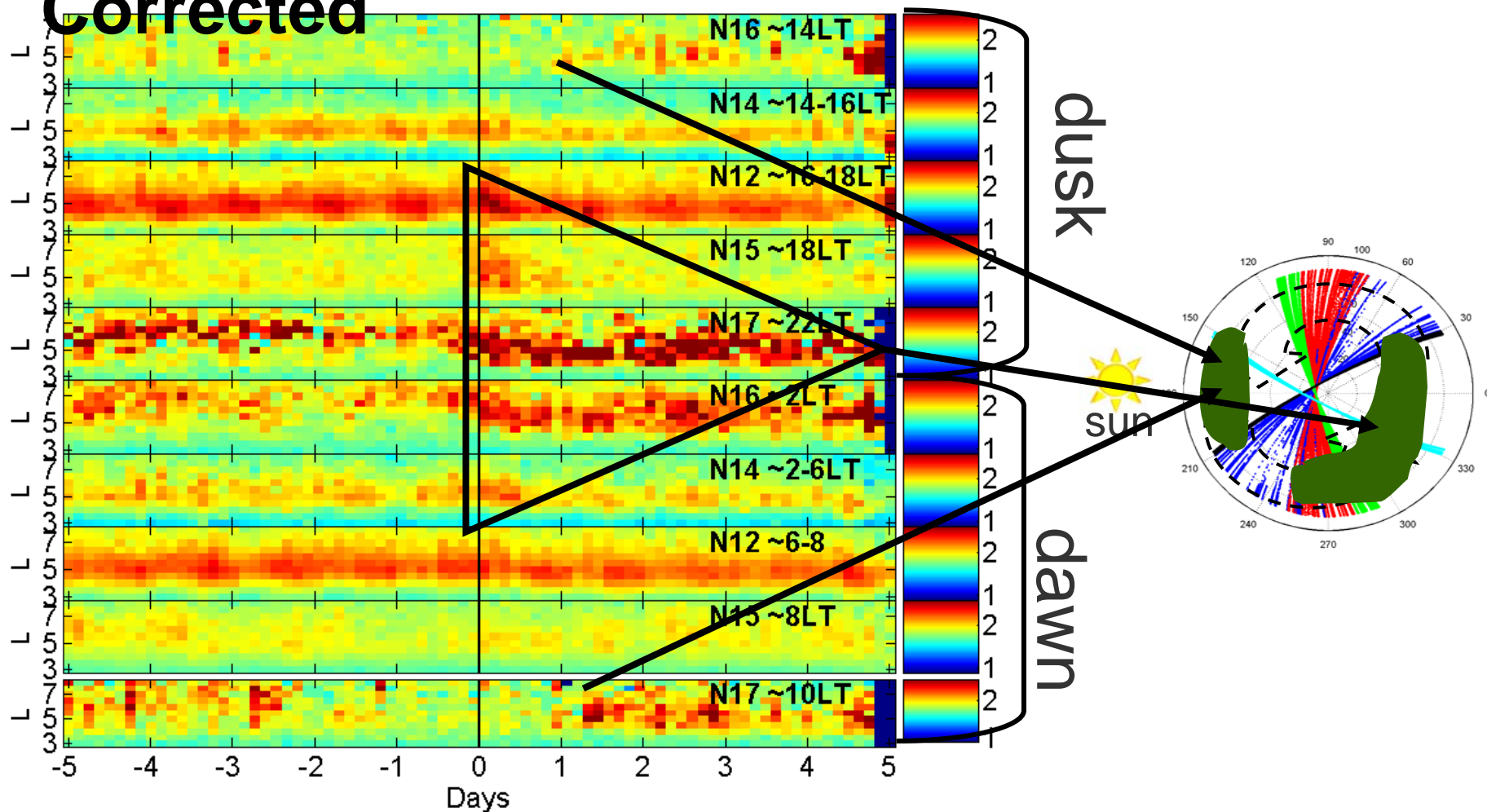

- Dayside precipitation from ~10-14 LT 1 day after the events start
- Dusk to midnight precipitation ~16-2 LT

# Cartoon of Precipitation

Precipitation  
occurs 1 day after  
start of events



sun

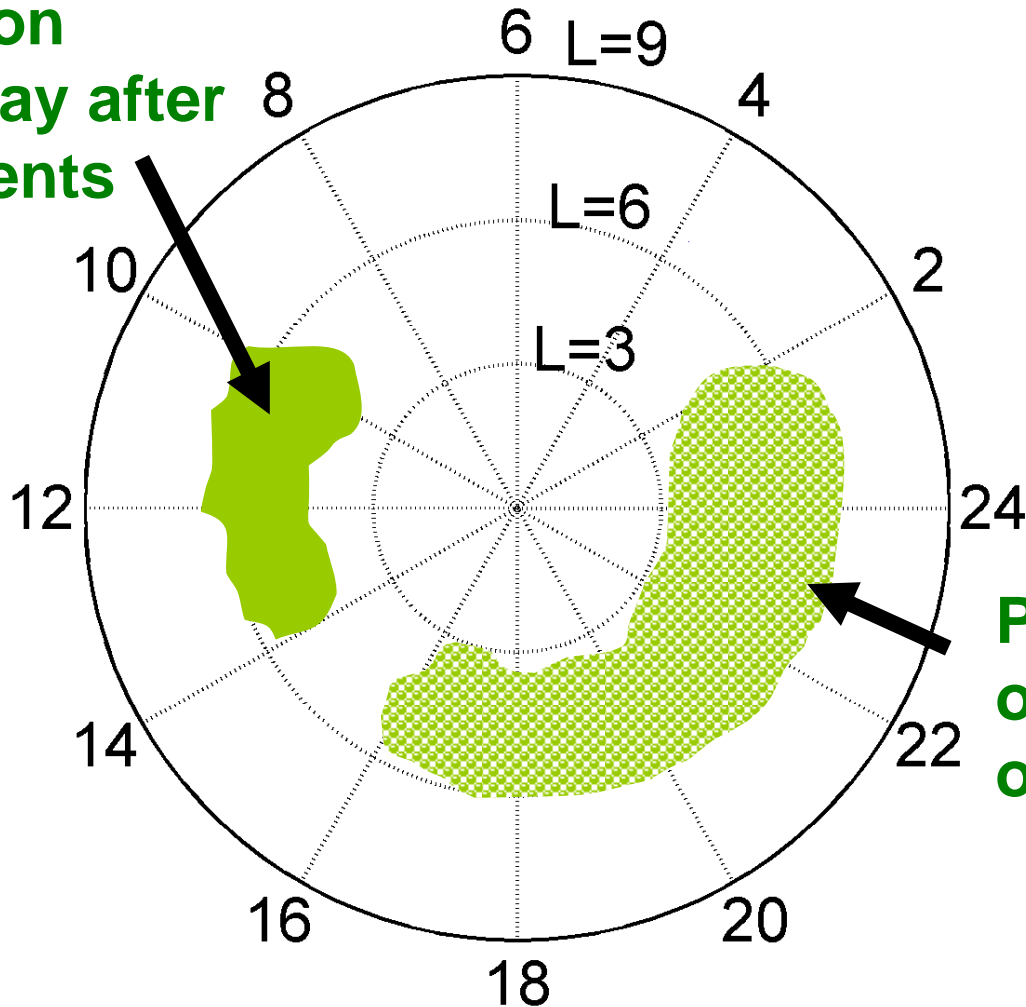

Precipitation  
occurs at start  
of events

# Waves vs. Precipitation



sun

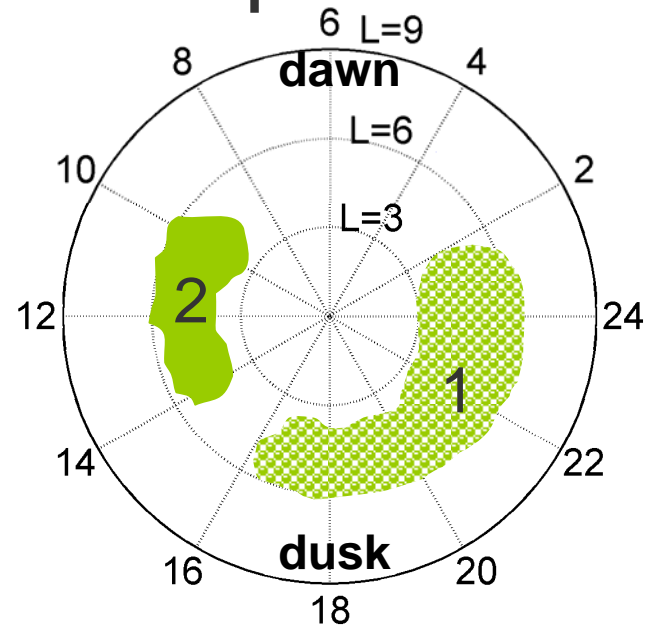
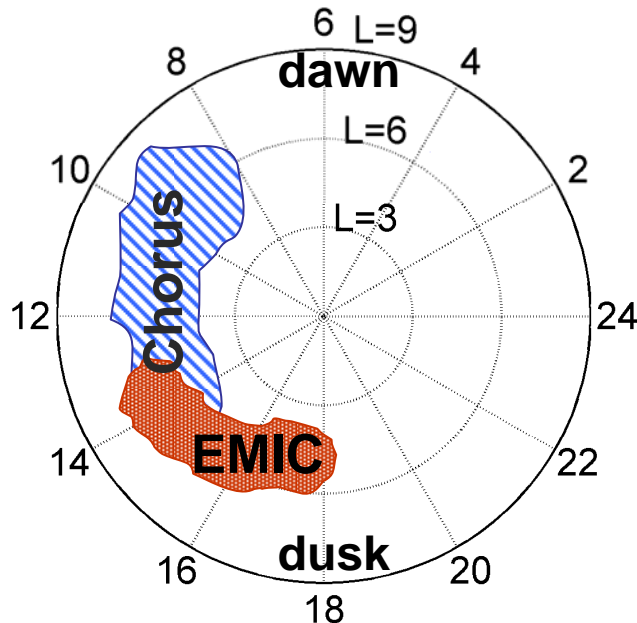

- Dayside precipitation (2) and chorus are observed at the same LT but the timing is off. (Possibly because the dayside POES data are from 2 satellites which were launched later and include only a few events.)
- Precipitation and EMIC waves are observed at dusk, but
  - No waves are observed in the nightside region where the most intense and prolonged precipitation occurs.

# What does all this mean for models?

- Acceleration: Mechanisms still uncertain but future missions will help.

- Simultaneous equatorial missions will measure radiation belt electron flux with detailed energy spectra and pitch angle distributions, along with magnetic fields.

- These comprehensive measurements will provide more accurate PSD estimates for differentiating between acceleration mechanisms.

Theorists are working on more detailed pitch angle distributions which can be compared to observations to differentiate between mechanisms

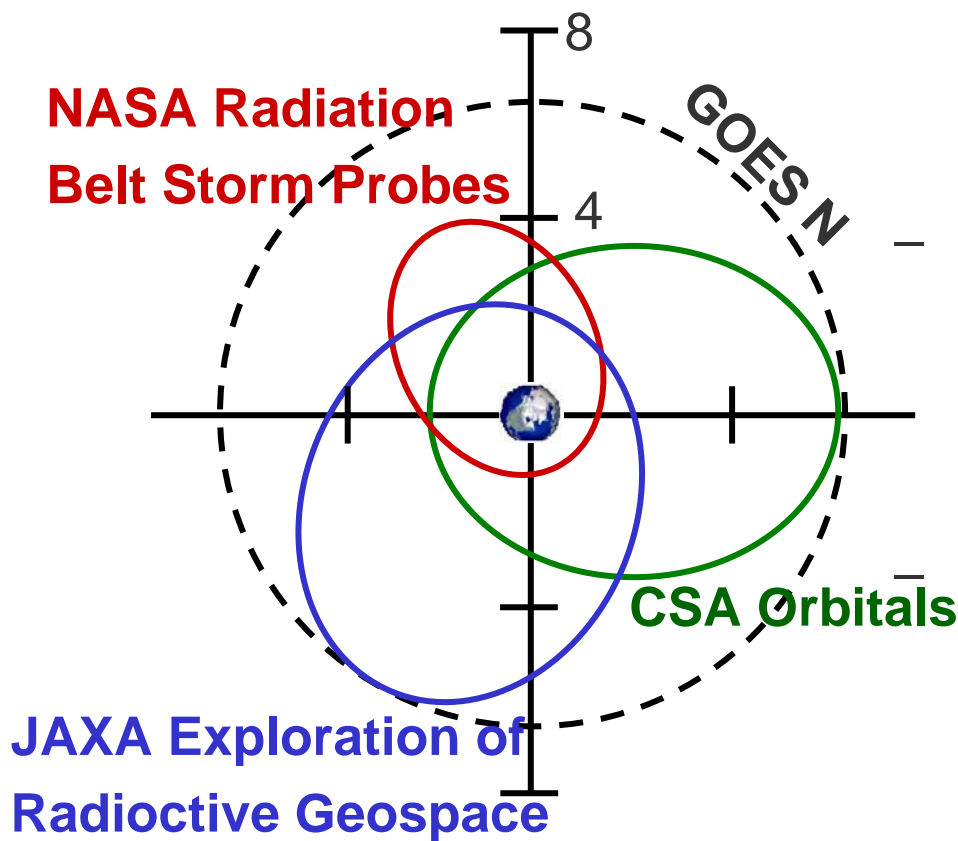

# What does all this mean for models?

- Loss: Precipitation appears to be a dominant loss mechanism. Models require information about wave power.

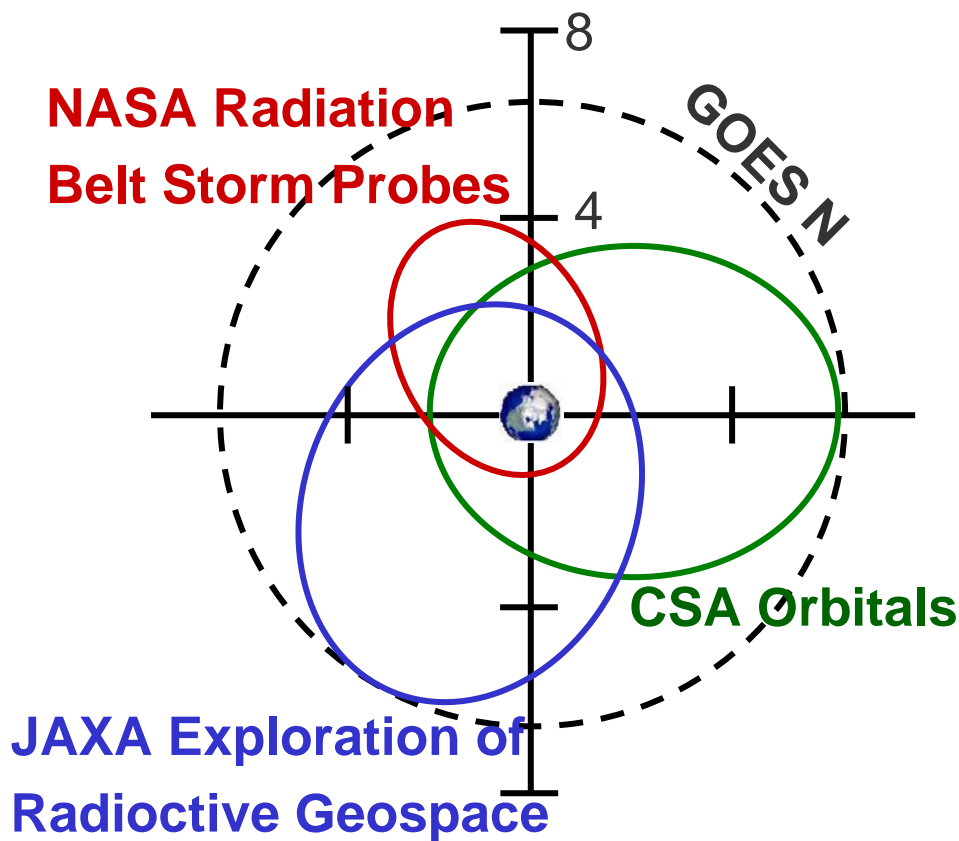

- Simultaneous equatorial missions will measure high and low frequency electric and magnetic wave power as a function of local time, radial distance and geomagnetic activity.

# What does all this mean for models?

- Loss: Precipitation appears to be a dominant loss mechanism. Future missions will help characterize wave power as a function of local time, radial distance and geomagnetic activity



# GOES PSD

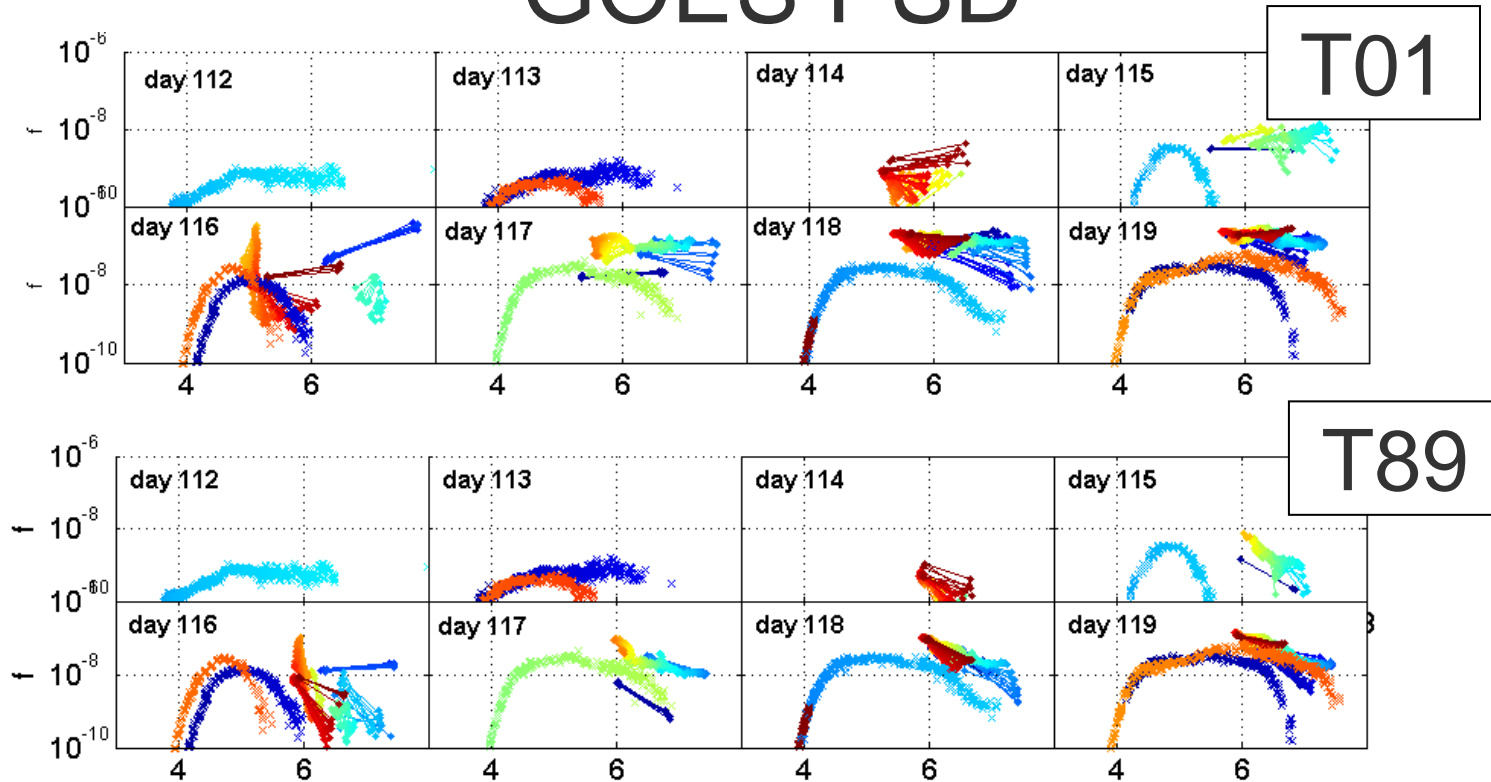

- **Problem 3:** Gradients depend on the magnetic field model.
  - The magnetic field from T96, T89 and T01 are all within 10% of the field measured locally at GOES. However, the equatorial fields (which are not measured) and the  $L^*$  estimates vary considerably.
- **Solution:** Consider events where the field is less disturbed and the models are more consistent.

# GOES PSD

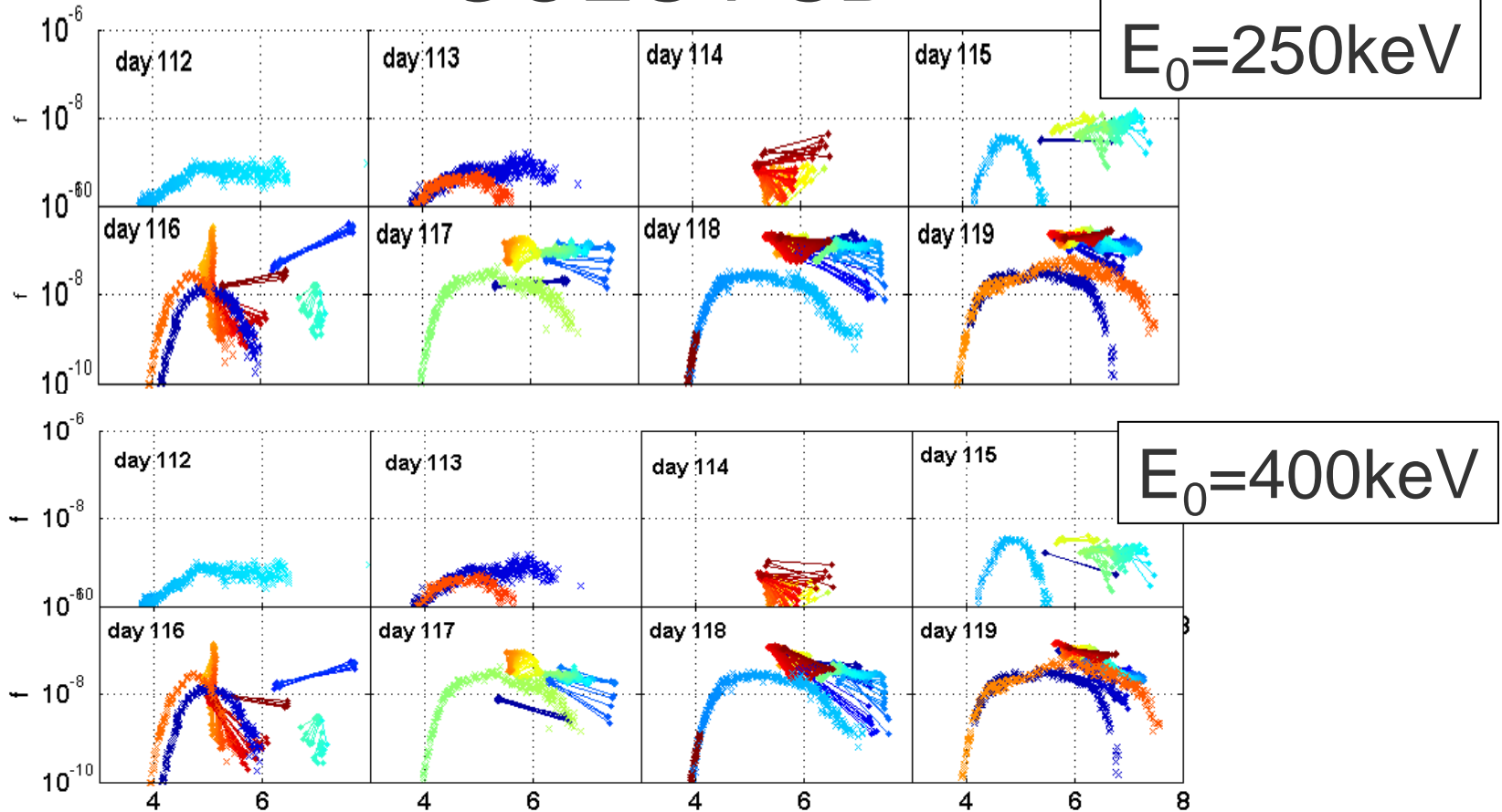

- **Problem 2:** Gradients are dependent on the energy spectra.
- **Solution:** Develop a more accurate model of the spectra that varies as a function of  $B$  using equatorial Polar and LANL data.

# The Earth's Radiation Belts

Discovered accidentally in 1958 by Dr. Van Allen's cosmic ray experiment onboard explorer I spacecraft.

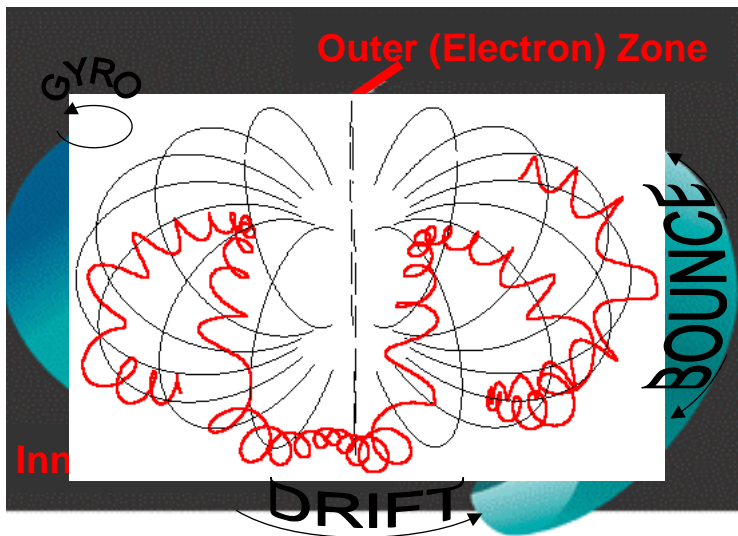

- Energies  $> .1$  MeV
- Inner belt 1.5-3  $R_e$ , Outer belt 3-10
- Slot region: flux minimum near  $\sim 3 R_e$  formed by enhanced precipitation due to interaction with whistler waves generated by lightning and VLF transmitters.
- Radiation belt electrons = relativistic electrons

*Goal: To understand and specify radiation belt variability.*

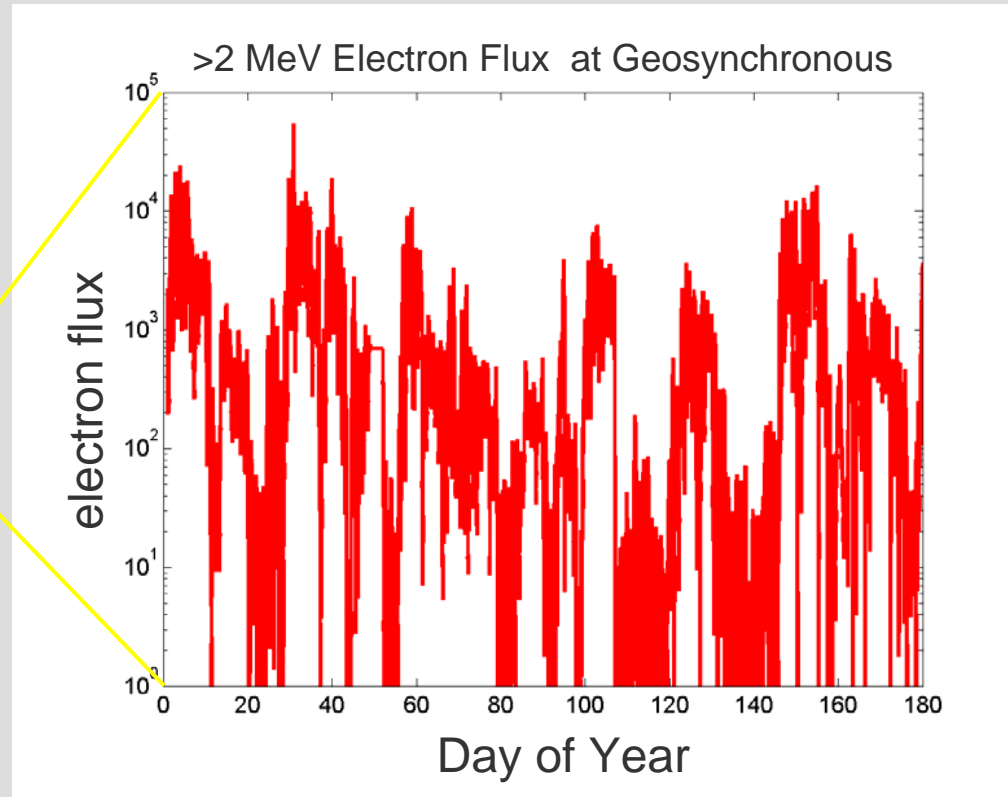
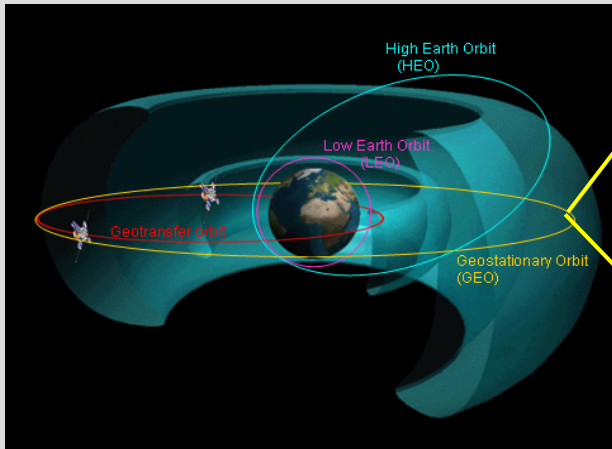

Contrary to intuition, relativistic electron flux does not always increase during geomagnetic storms [*Reeves et al., 2003*]

Flux levels are determined by the outcome of a continuous competition between acceleration and loss.

## External: ULF wave induced radial diffusion

vs.

## Internal: whistler wave induced pitch angle and energy diffusion

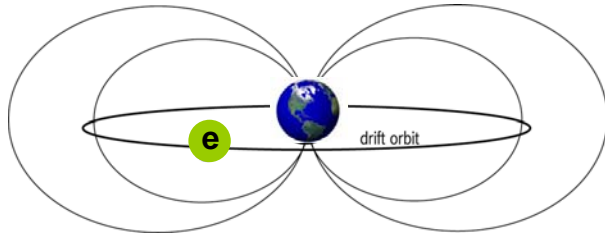

- Electrons drifting at the right frequency will resonate with the ULF wave.
- The electron experiences a constant electric field that moves it radially in or out depending on the waves phase.
- A positive PSD gradient will produce net inward electron motion and acceleration.

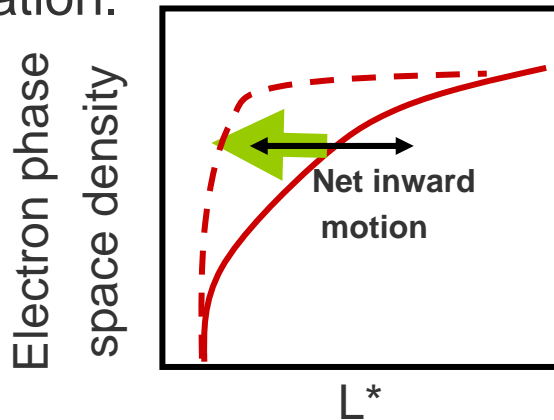

- Electrons gyrating at the right frequency will resonate with the VLF whistler wave.
- The electron experiences a constant electric field that moves it in pitch angle and energy.
- Electrons moving towards 90 gain energy.

# Goal: To Better understand and specify radiation belt variability

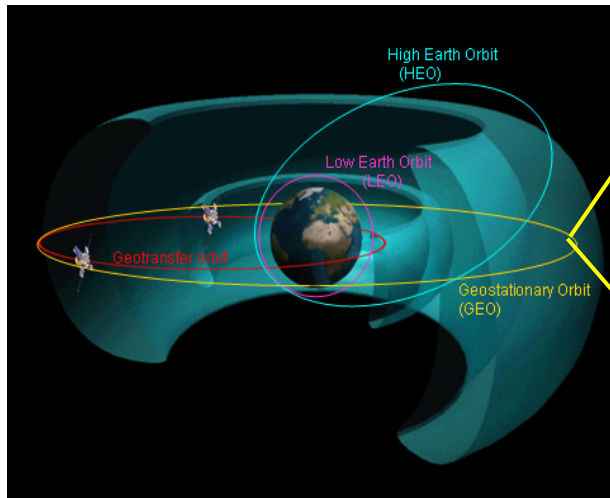

>2 MeV Electron Flux at Geosynchronous

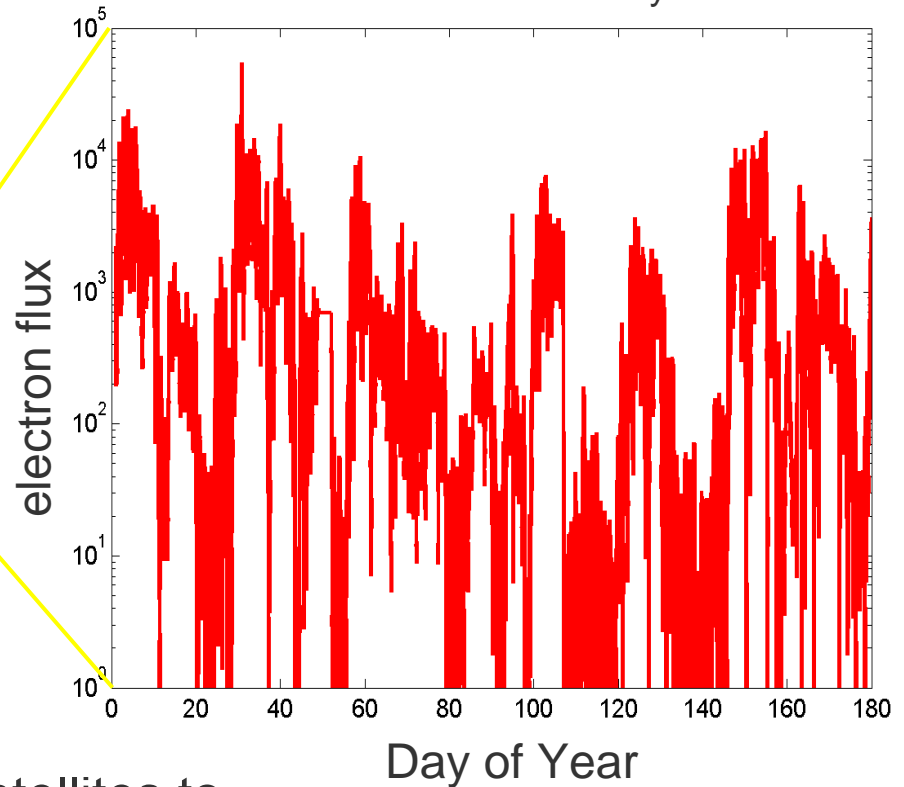

High radiation levels may cause satellites to electrically charge. A sudden discharge may cause minor problems, temporarily disabling satellites due to flipped program bits or more cataclysmic situations, permanently satellites due to damaged electronics.

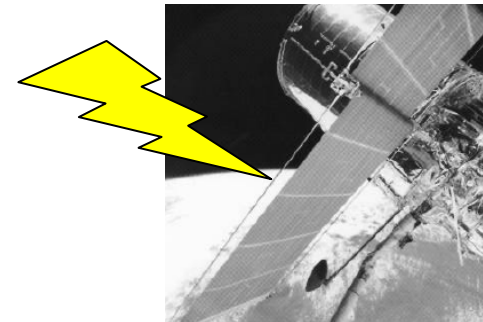

# Polar PSD gradients

- PSD estimates based on data taken from dayside measurements show peaks near  $L^* \sim 5$ . They are not highly dependent on the chosen field model.
- Nightside estimates are highly dependent on the field model, particularly the amount of stretching.
- An overstretched model produces high PSD estimates. An understretched model produces low estimates.

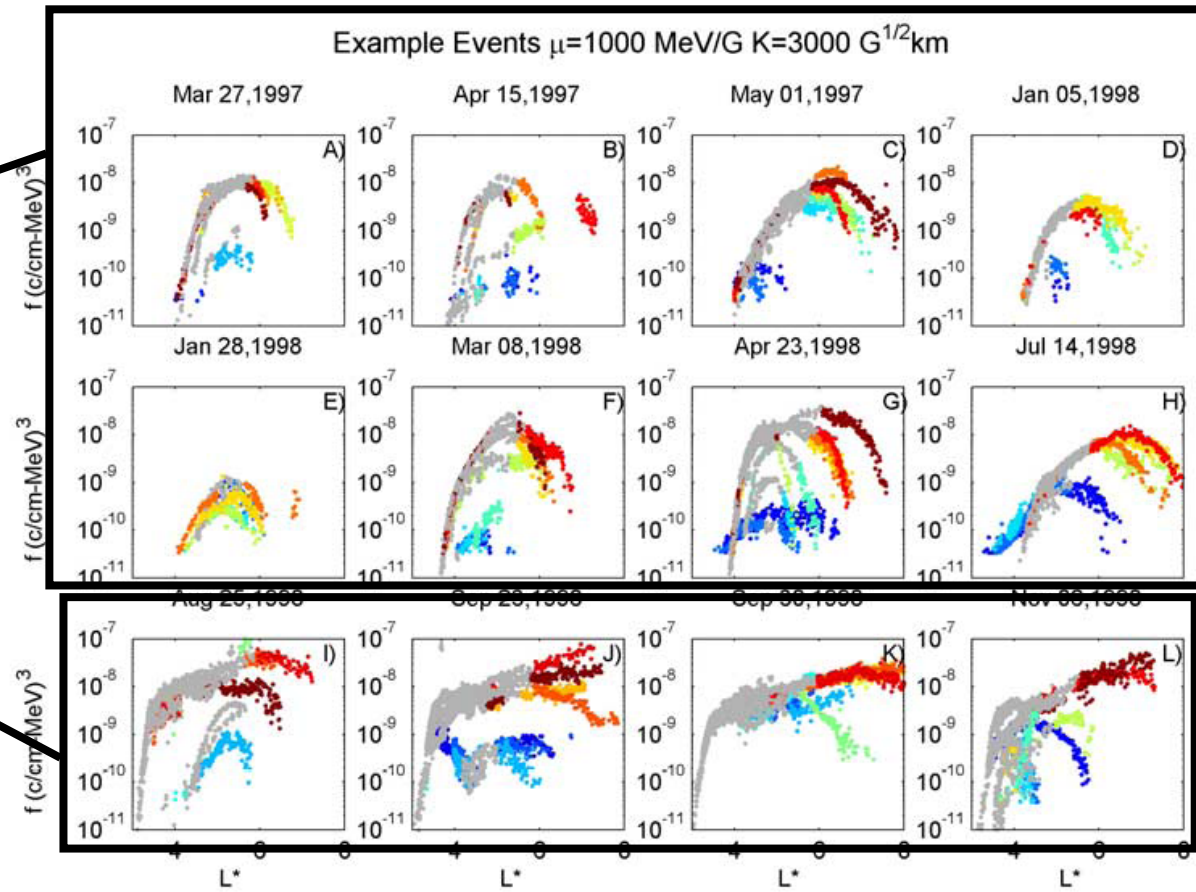

*Dayside PSD estimates are more robust to field model changes and indicate local acceleration at  $L^* \sim 5$*



# GOES PSD calculation

- 1) Relate integral flux to PSD 
$$J(> 2MeV) = \int_{2MeV}^{\infty} dE' f(e') p^2$$
- 2) Solve the integral analytically for  $f(2MeV)$  assuming  $f(E)=f_0 \exp(-E/E_0)$  and determine  $f_0$

-  ***$E_0$  is not measured by GOES but varies from 250-400 keV based on Polar and LANL data.***

$$f(2MeV) = \frac{c^2 J(> 2MeV)}{(E_0^2 + EE_0) 2mc^2 + 2E_0^3 + 2EE_0^2 + E^2 E_0}$$

- 3) Find  $f(2MeV)$  at the equator (second invariant=0) assuming the pitch angle distribution varies as  $\sin^m(\alpha_{eq})$ .  
- ***Pitch angle distributions are only measured during limited times when the satellites freely tumble in storage mode. This data is used to define how  $m$  varies with magnetic field strength.***
- 4) Find the energy,  $E_{\mu}$  which corresponds to constant  $\mu=p^2/2m_0B$ . Find  $f(E_{\mu})=f_0 \exp(-E_{\mu}/E_0)$
- 5) Trace the particle drift around the earth and calculate the flux enclosed to determine the third invariant  $L^*$ . [Onsager et al., 2004]



- Dayside pitch angle distributions are peaked at  $90^\circ$ .
- Nightside distributions are butterfly shaped.

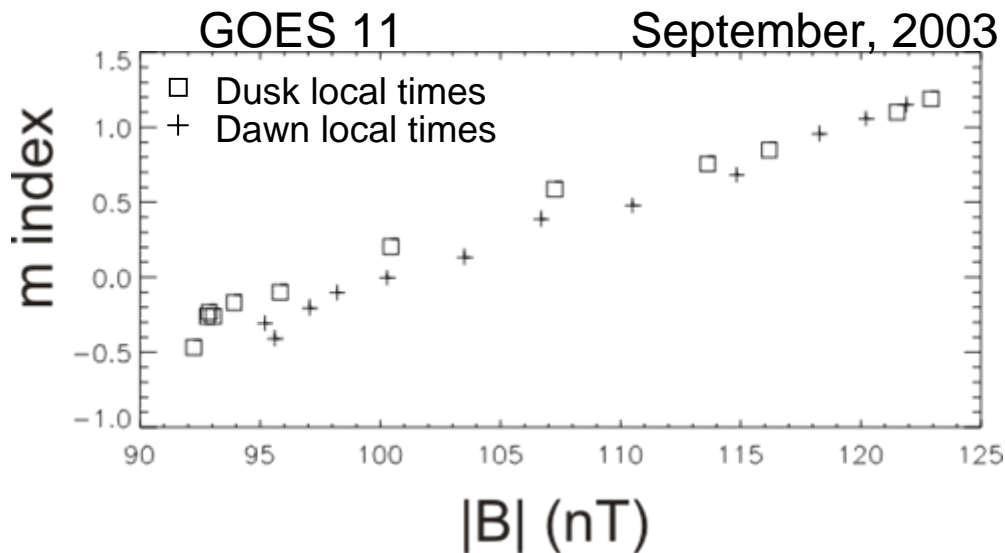
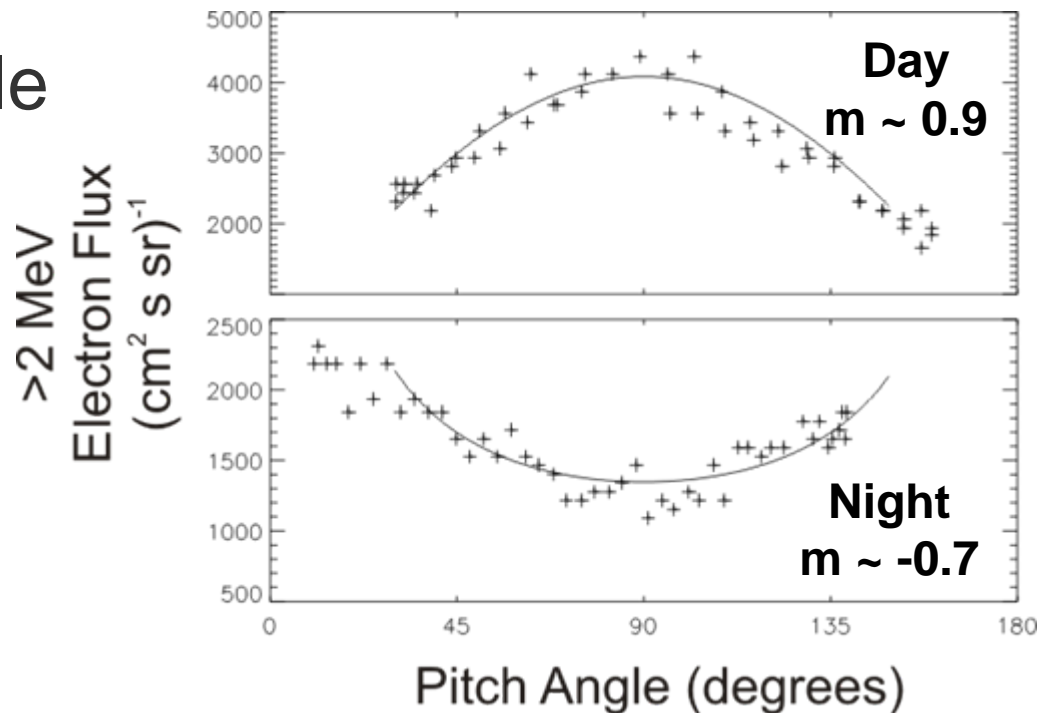

- $m$  varies as a function of  $B$

Onsager et al., [2004]